



An Oshkosh Corporation Company

Operation and Safety Manual

Original Instructions - Keep this manual with the machine at all times.

Boom Lift Models

E300AJ

E300AJP

S/N 0300138358 to Present



3121252
August 9, 2012

FOREWORD

This manual is a very important tool! Keep it with the machine at all times.

The purpose of this manual is to provide owners, users, operators, lessors, and lessees with the precautions and operating procedures essential for the safe and proper machine operation for its intended purpose.

Due to continuous product improvements, JLG Industries, Inc. reserves the right to make specification changes without prior notification. Contact JLG Industries, Inc. for updated information.

SAFETY ALERT SYMBOLS AND SAFETY SIGNAL WORDS



This is the Safety Alert Symbol. It is used to alert you to the potential personal injury hazards. Obey all safety messages that follow this symbol to avoid possible injury or death

DANGER

INDICATES AN IMMINENTLY HAZARDOUS SITUATION. IF NOT AVOIDED, WILL RESULT IN SERIOUS INJURY OR DEATH. THIS DECAL WILL HAVE A RED BACKGROUND.

WARNING

INDICATES A POTENTIALLY HAZARDOUS SITUATION. IF NOT AVOIDED, COULD RESULT IN SERIOUS INJURY OR DEATH. THIS DECAL WILL HAVE AN ORANGE BACKGROUND.

CAUTION

INDICATES A POTENTIALLY HAZARDOUS SITUATION. IF NOT AVOIDED, MAY RESULT IN MINOR OR MODERATE INJURY. IT MAY ALSO ALERT AGAINST UNSAFE PRACTICES. THIS DECAL WILL HAVE A YELLOW BACKGROUND.

NOTICE

INDICATES INFORMATION OR A COMPANY POLICY THAT RELATES DIRECTLY OR INDIRECTLY TO THE SAFETY OF PERSONNEL OR PROTECTION OF PROPERTY.

⚠ WARNING

THIS PRODUCT MUST COMPLY WITH ALL SAFETY RELATED BULLETINS. CONTACT JLG INDUSTRIES, INC. OR THE LOCAL AUTHORIZED JLG REPRESENTATIVE FOR INFORMATION REGARDING SAFETY-RELATED BULLETINS WHICH MAY HAVE BEEN ISSUED FOR THIS PRODUCT.

NOTICE

JLG INDUSTRIES, INC. SENDS SAFETY RELATED BULLETINS TO THE OWNER OF RECORD OF THIS MACHINE. CONTACT JLG INDUSTRIES, INC. TO ENSURE THAT THE CURRENT OWNER RECORDS ARE UPDATED AND ACCURATE.

NOTICE

JLG INDUSTRIES, INC. MUST BE NOTIFIED IMMEDIATELY IN ALL INSTANCES WHERE JLG PRODUCTS HAVE BEEN INVOLVED IN AN ACCIDENT INVOLVING BODILY INJURY OR DEATH OF PERSONNEL OR WHEN SUBSTANTIAL DAMAGE HAS OCCURRED TO PERSONAL PROPERTY OR THE JLG PRODUCT.

For:

- Accident Reporting
- Product Safety Publications
- Current Owner Updates
- Questions Regarding Product Safety
- Standards and Regulations Compliance Information
- Questions Regarding Special Product Applications
- Questions Regarding Product Modifications

Contact:

Product Safety and Reliability Department
JLG Industries, Inc.
13224 Fountainhead Plaza
Hagerstown, MD 21742
USA

or Your Local JLG Office
(See addresses on inside of manual cover)

In USA:

Toll Free: 877-JLG-SAFE (877-554-7233)

Outside USA:

Phone: 240-420-2661
Fax: 301-745-3713
E-mail: ProductSafety@JLG.com

REVISION LOG

Original Issue	- June 26, 2009
Revised	- September 29, 2009
Revised	- October 28, 2009
Revised	- November 19, 2009
Revised	- November 8, 2010
Revised	- February 6, 2012
Revised	- August 9, 2012

SECTION - PARAGRAPH, SUBJECT	PAGE
SECTION - 1 - SAFETY PRECAUTIONS	
1.1 GENERAL	1-1
1.2 PRE-OPERATION	1-1
Operator Training and Knowledge	1-1
Workplace Inspection	1-2
Machine Inspection	1-2
1.3 OPERATION	1-3
General	1-3
Trip and Fall Hazards	1-3
Electrocution Hazards	1-4
Tipping Hazards	1-6
Crushing and Collision Hazards	1-7
1.4 TOWING, LIFTING, AND HAULING	1-8
1.5 ADDITIONAL HAZARDS / SAFETY	1-9
SECTION - 2 - USER RESPONSIBILITIES, MACHINE PREPARATION, AND INSPECTION	
2.1 PERSONNEL TRAINING	2-1
Operator Training	2-1
Training Supervision	2-1
Operator Responsibility	2-1
2.2 PREPARATION, INSPECTION, AND MAINTENANCE	2-2
Pre-Start Inspection	2-4
Function Check	2-5

SECTION - PARAGRAPH, SUBJECT	PAGE
General	2-9
SECTION - 3 - MACHINE CONTROLS AND INDICATORS	
3.1 GENERAL	3-1
3.2 CONTROLS AND INDICATORS	3-1
Ground Control Station	3-2
Platform Station	3-7
Platform Control Indicator Panel	3-11
SECTION - 4 - MACHINE OPERATION	
4.1 DESCRIPTION	4-1
4.2 BOOM OPERATING CHARACTERISTICS AND LIMITATIONS	4-2
Capacities	4-2
Stability	4-2
4.3 MOTOR OPERATION	4-6
Power/Emergency Stop Switch	4-6
Platform/Ground Select Switch	4-6
Motor Activation	4-6
4.4 TRAVELING (DRIVING)	4-7
Traveling Forward and Reverse	4-9
4.5 STEERING	4-9
4.6 PLATFORM	4-9
Platform Level Adjustment	4-9
Platform Rotation	4-9

TABLE OF CONTENTS

SECTION - PARAGRAPH, SUBJECT	PAGE
4.7 BOOM	4-10
Swinging the Boom	4-11
Raising and Lowering the Upper Boom	4-11
4.8 FUNCTION SPEED CONTROL	4-11
4.9 SHUT DOWN AND PARK	4-11
4.10 LIFTING AND TIE DOWN.	4-12
Lifting	4-12
Tie Down	4-12
SECTION - 5 - EMERGENCY PROCEDURES	
5.1 GENERAL	5-1
5.2 INCIDENT NOTIFICATION.	5-1
5.3 EMERGENCY OPERATION.	5-1
Operator Unable to Control Machine	5-1
Platform or Boom Caught Overhead.	5-2
5.4 EMERGENCY TOWING PROCEDURES	5-2
5.5 MANUAL DESCENT SYSTEM.	5-2
5.6 MANUAL SWING OVERRIDE	5-4
SECTION - 6 - GENERAL SPECIFICATIONS & OPERATOR MAINTENANCE	
6.1 INTRODUCTION	6-1
6.2 OPERATING SPECIFICATIONS AND PERFORMANCE DATA	6-1
Operating Specifications	6-1

SECTION - PARAGRAPH, SUBJECT	PAGE
Dimensional Data	6-2
Capacities	6-3
Tires	6-3
Hydraulic Oil	6-4
Major Component Weights.	6-7
6.3 OPERATOR MAINTENANCE	6-9
6.4 BATTERY MAINTENANCE AND CHARGING.	6-13
Battery Maintenance, Quarterly	6-13
Battery Charging, Daily.	6-14
6.5 TIRES & WHEELS	6-15
Tire Replacement	6-15
Wheel and Tire Replacement	6-15
Wheel Installation	6-15
6.6 SUPPLEMENTAL INFORMATION	6-16
SECTION - 7 - INSPECTION AND REPAIR LOG	
LIST OF FIGURES	
2-1. Basic Nomenclature.	2-7
2-2. Daily Walk-Around Inspection - Sheet 1 of 3	2-8
2-3. Daily Walk-Around Inspection - Sheet 2 of 3	2-9
2-4. Daily Walk-Around Inspection - Sheet 3 of 3	2-10
3-1. Ground Control Station - E300AJ	3-3
3-2. Ground Control Station - E300AJP	3-4

SECTION - PARAGRAPH, SUBJECT	PAGE
3-2. Platform Control Console	3-8
3-3. Platform Control Indicator Panel	3-12
4-1. Position of Least Forward Stability	4-3
4-2. Position of Least Backward Stability - E300AJ	4-4
4-3. Position of Least Backward Stability - E300AJP	4-5
4-4. Grade and Side Slopes	4-8
4-5. Lifting and Tie Down Chart	4-13
4-6. Decal Location Sheet 1 of 5	4-14
4-7. Decal Location Sheet 2 of 5	4-15
4-8. Decal Location Sheet 3 of 5	4-16
4-9. Decal Location Sheet 4 of 5	4-17
4-10. Decal Location Sheet 5 of 5	4-18
5-1. Manual Descent Location	5-3
6-1. Operator Maintenance and Lubrication Diagram	6-8

SECTION - PARAGRAPH, SUBJECT	PAGE
LIST OF TABLES	
1-1 Minimum Approach Distances (M.A.D.)	1-5
1-2 Beaufort Scale (For Reference Only)	1-10
2-1 Inspection and Maintenance Table	2-3
6-1 Operating specifications - E300AJ	6-1
6-2 Operating specifications - E300AJP	6-2
6-3 Dimensional Data - E300AJ	6-2
6-4 Dimensional Data - E300AJP	6-3
6-5 Capacities	6-3
6-6 Tires	6-3
6-7 Hydraulic Oil	6-4
6-8 Mobil DTE 11M Specs	6-4
6-9 Mobilfluid 424 Specs	6-5
6-10 Mobil EAL 224H Specs	6-5
6-11 Mobil EAL EnviroSyn H Specs	6-6
6-12 Quintolubric 888-46	6-6
6-13 Critical Stability Weights	6-7
6-14 Lubrication Specifications	6-9
6-15 Wheel Torque Chart	6-16
7-1 Inspection and Repair Log	7-1

TABLE OF CONTENTS

SECTION - PARAGRAPH, SUBJECT

PAGE

SECTION - PARAGRAPH, SUBJECT

PAGE

This page left blank intentionally.

SECTION 1. SAFETY PRECAUTIONS

1.1 GENERAL

This section outlines the necessary precautions for proper and safe machine operation and maintenance. For proper machine use, it is mandatory that a daily routine is established based on the content of this manual. A maintenance program, using the information provided in this manual and the Service and Maintenance Manual, must also be established by a qualified person and followed to ensure the machine is safe to operate.

The owner/user/operator/lessor/lessee of the machine should not operate the machine until this manual has been read, training is accomplished, and operation of the machine has been completed under the supervision of an experienced and qualified operator.

If there are any questions with regard to safety, training, inspection, maintenance, application, and operation, please contact JLG Industries, Inc. ("JLG").

WARNING

FAILURE TO COMPLY WITH THE SAFETY PRECAUTIONS LISTED IN THIS MANUAL COULD RESULT IN MACHINE DAMAGE, PROPERTY DAMAGE, PERSONAL INJURY OR DEATH.

1.2 PRE-OPERATION

Operator Training and Knowledge

- Read and understand this manual before operating the machine.

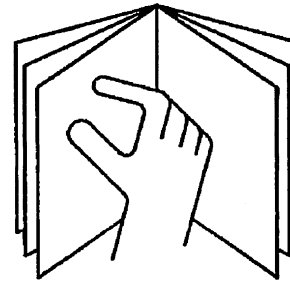

- Do not operate this machine until complete training is performed by authorized persons.
- Only authorized and qualified personnel can operate the machine.

SECTION 1 - SAFETY PRECAUTIONS

- Read, understand, and obey all DANGERS, WARNINGS, CAUTIONS, and operating instructions on the machine and in this manual.
- Use the machine in a manner which is within the scope of its intended application set by JLG.
- All operating personnel must be familiar with the emergency controls and emergency operation of the machine as specified in this manual.
- Read, understand, and obey all applicable employer, local, and governmental regulations as they pertain to operation of the machine.

Workplace Inspection

- The operator is to take safety measures to avoid all hazards in the work area prior to machine operation.
- Do not operate or raise the platform while on trucks, trailers, railway cars, floating vessels, scaffolds or other equipment unless approved in writing by JLG.
- Do not operate the machine in hazardous environments unless approved for that purpose by JLG.
- Be sure that the ground conditions are able to support the maximum load shown on the decals located on the machine.

Machine Inspection

- Before machine operation, perform inspections and functional checks. Refer to Section 2 of this manual for detailed instructions.
- Do not operate this machine until it has been serviced and maintained according to requirements specified in the Service and Maintenance Manual.
- Be sure the footswitch and all other safety devices are operating properly. Modification of these devices is a safety violation.

WARNING

MODIFICATION OR ALTERATION OF AN AERIAL WORK PLATFORM SHALL BE MADE ONLY WITH WRITTEN PERMISSION FROM THE MANUFACTURER

- Do not operate any machine on which safety or instruction placards or decals are missing or illegible.
- Avoid any buildup of debris on the platform floor. Keep mud, oil, grease, and other slippery substances from footwear and platform floor.

1.3 OPERATION

General

- Do not use the machine for any purpose other than positioning personnel, their tools, and equipment.
 - Never operate a machine that is not working properly. If a malfunction occurs, shut down the machine.
 - Never slam a control switch or lever through neutral to an opposite direction. Always return switch to neutral and stop before moving the switch to the next function. Operate controls with slow and even pressure.
 - Do not allow personnel to tamper with or operate the machine from the ground with personnel in the platform, except in an emergency.
 - Do not carry materials directly on platform railing. Contact JLG for approved material handling accessories.
 - When two or more persons are in the platform, the operator shall be responsible for all machine operations.
 - Always ensure that power tools are properly stowed and never left hanging by their cord from the platform work area.
- Supplies or tools which extend outside the platform are prohibited unless approved by JLG.
 - When driving, always position boom over rear axle in line with the direction of travel. Remember, if boom is over the front axle, steer and drive functions will be reversed.
 - Do not assist a stuck or disabled machine by pushing, pulling, or by using boom functions. Only pull the unit from the tie-down lugs on the chassis.
 - Do not place boom or platform against any structure to steady the platform or to support the structure.
 - Stow boom and shut off all power before leaving machine.

Trip and Fall Hazards

During operation, occupants in the platform must wear a full body harness with a lanyard attached to an authorized lanyard anchorage point. Attach only one (1) lanyard per lanyard anchorage point.

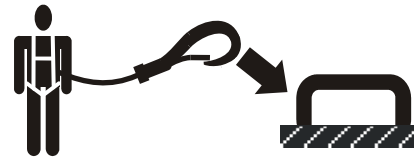

SECTION 1 - SAFETY PRECAUTIONS

- Before operating the machine, make sure all gates are closed and fastened in their proper position.

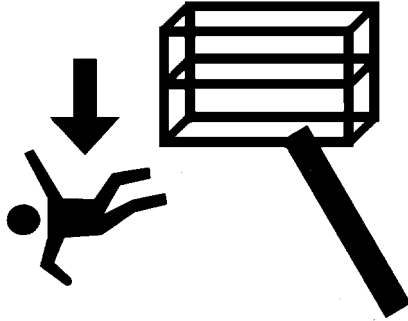

- Keep both feet firmly positioned on the platform floor at all times. Never use ladders, boxes, steps, planks, or similar items on platform to provide additional reach.
- Never use the boom assembly to enter or leave the platform.

- Use extreme caution when entering or leaving platform. Be sure that the boom is fully lowered. It may be necessary to telescope out to position the platform closer to the ground for entry/exit. Face the machine, maintain “three point contact” with the machine, using two hands and one foot or two feet and one hand during entry and exit.

Electrocution Hazards

- This machine is not insulated and does not provide protection from contact or proximity to electrical current.

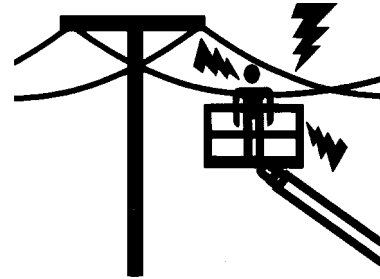

SECTION 1 - SAFETY PRECAUTIONS

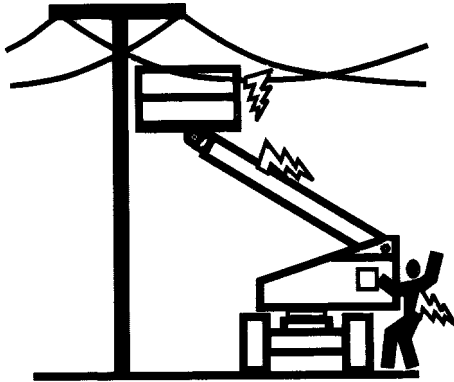

- Maintain distance from electrical lines, apparatus, or any energized (exposed or insulated) parts according to the Minimum Approach Distance (MAD) as shown in Table 1-1.
- Allow for machine movement and electrical line swaying.

Table 1-1. Minimum Approach Distances (M.A.D.)

Voltage Range (Phase to Phase)	MINIMUM APPROACH DISTANCE in Feet (Meters)
0 to 50 KV	10 (3)
Over 50KV to 200 KV	15 (5)
Over 200 KV to 350 KV	20 (6)
Over 350 KV to 500 KV	25 (8)
Over 500 KV to 750 KV	35 (11)
Over 750 KV to 1000 KV	45 (14)

NOTE: *This requirement shall apply except where employer, local or governmental regulations are more stringent.*

- Maintain a clearance of at least 10 ft. (3m) between any part of the machine and its occupants, their tools, and their equipment from any electrical line or apparatus carrying up to 50,000 volts. One foot additional clearance is required for every additional 30,000 volts or less.

SECTION 1 - SAFETY PRECAUTIONS

- The minimum approach distance may be reduced if insulating barriers are installed to prevent contact, and the barriers are rated for the voltage of the line being guarded. These barriers shall not be part of (or attached to) the machine. The minimum approach distance shall be reduced to a distance within the designed working dimensions of the insulating barrier. This determination shall be made by a qualified person in accordance with the employer, local, or governmental requirements for work practices near energized equipment

⚠ DANGER

DO NOT MANEUVER MACHINE OR PERSONNEL INSIDE PROHIBITED ZONE (MAD). ASSUME ALL ELECTRICAL PARTS AND WIRING ARE ENERGIZED UNLESS KNOWN OTHERWISE.

Tipping Hazards

- The user must be familiar with the surface before driving. Do not exceed the allowable sideslope and grade while driving.

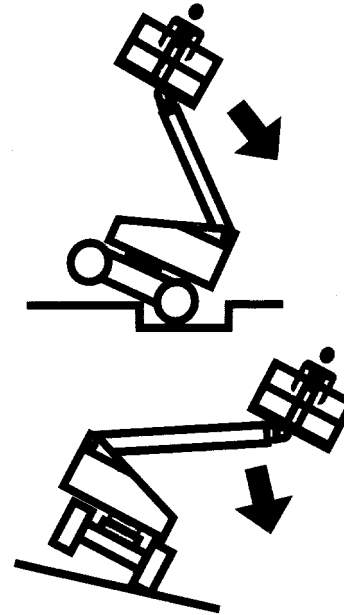

- Do not elevate platform or drive with platform elevated while on a sloping, uneven, or soft surface.
- Before driving on floors, bridges, trucks, and other surfaces, check allowable capacity of the surfaces.
- Never exceed the maximum platform capacity. Distribute loads evenly on platform floor.
- Do not raise the platform or drive from an elevated position unless the machine is on firm, level and smooth surfaces.
- Keep the chassis of the machine at least 2 ft. (0.6m) from holes, bumps, drop-offs, obstructions, debris, concealed holes, and other potential hazards on the floor/surface.
- Do not push or pull any object with the boom.
- Never attempt to use the machine as a crane. Do not tie-off machine to any adjacent structure.
- Do not operate the machine when wind conditions exceed 28 mph (12.5 m/s). Refer to Table 1-2, Beaufort Scale (For Reference Only).
- Do not increase the surface area of the platform or the load. Increase of the area exposed to the wind will decrease stability.
- Do not increase the platform size with unauthorized deck extensions or attachments.

- If boom assembly or platform is in a position that one or more wheels are off the ground, all persons must be removed before attempting to stabilize the machine. Use cranes, forklift trucks, or other appropriate equipment to stabilize machine.

Crushing and Collision Hazards

- Approved head gear must be worn by all operating and ground personnel.
- Check work area for clearances overhead, on sides, and bottom of platform when lifting or lowering platform, and driving.

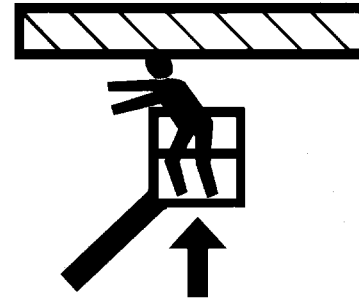

- During operation, keep all body parts inside platform railing.

SECTION 1 - SAFETY PRECAUTIONS

- Use the boom functions, not the drive function, to position the platform close to obstacles.
- Always post a lookout when driving in areas where vision is obstructed.
- Keep non-operating personnel at least 6 ft. (1.8m) away from machine during all driving and swing operations.
- Limit travel speed according to conditions of ground surface, congestion, visibility, slope, location of personnel, and other factors which may cause collision or injury to personnel.
- Be aware of stopping distances in all drive speeds. When driving in high speed, switch to low speed before stopping. Travel grades in low speed only.
- Do not use high speed drive in restricted or close quarters or when driving in reverse.
- Exercise extreme caution at all times to prevent obstacles from striking or interfering with operating controls and persons in the platform.
- Be sure that operators of other overhead and floor level machines are aware of the aerial work platform's presence. Disconnect power to overhead cranes.
- Warn personnel not to work, stand, or walk under a raised boom or platform. Position barricades on floor if necessary.

1.4 TOWING, LIFTING, AND HAULING

- Never allow personnel in platform while towing, lifting, or hauling.
- This machine should not be towed, except in the event of emergency, malfunction, power failure, or loading/unloading. Refer to the Emergency Procedures section of this manual for emergency towing procedures.
- Ensure boom is in the stowed position and the turntable locked prior to towing, lifting or hauling. The platform must be completely empty of tools.
- When lifting machine, lift only at designated areas of the machine. Lift the unit with equipment of adequate capacity.
- Refer to the Machine Operation section of this manual for lifting information.

1.5 ADDITIONAL HAZARDS / SAFETY

- Do not use machine as a ground for welding.
- When performing welding or metal cutting operations, precautions must be taken to protect the chassis from direct exposure to weld and metal cutting spatter.
- Do not refuel the machine with the engine running.
- Battery fluid is highly corrosive. Avoid contact with skin and clothing at all times.
- Charge batteries only in a well ventilated area.

SECTION 1 - SAFETY PRECAUTIONS

NOTICE

DO NOT OPERATE THE MACHINE WHEN WIND CONDITIONS EXCEED 28 MPH (12.5 M/S).

Table 1-2. Beaufort Scale (For Reference Only)

Beaufort Number	Wind Speed		Description	Land Conditions
	mph	m/s		
0	0	0-0.2	Calm	Calm. Smoke rises vertically
1	1-3	0.3-1.5	Light air	Wind motion visible in smoke
2	4-7	1.6-3.3	Light breeze	Wind felt on exposed skin. Leaves rustle
3	8-12	3.4-5.4	Gentle breeze	Leaves and smaller twigs in constant motion
4	13-18	5.5-7.9	Moderate breeze	Dust and loose paper raised. Small branches begin to move.
5	19-24	8.0-10.7	Fresh breeze	Smaller trees sway.
6	25-31	10.8-13.8	Strong breeze	Large branches in motion. Whistling heard in overhead wires. Umbrella use becomes difficult.
7	32-38	13.9-17.1	Near Gale/Moderate Gale	Whole trees in motion. Effort needed to walk against the wind.
8	39-46	17.2-20.7	Fresh Gale	Twigs broken from trees. Cars veer on road.
9	47-54	20.8-24.4	Strong Gale	Light structure damage.

SECTION 2. USER RESPONSIBILITIES, MACHINE PREPARATION, AND INSPECTION

2.1 PERSONNEL TRAINING

The aerial platform is a personnel handling device; so it is necessary that it be operated and maintained only by trained personnel.

Persons under the influence of drugs or alcohol or who are subject to seizures, dizziness or loss of physical control must not operate this machine.

Operator Training

Operator training must cover:

1. Use and limitations of the controls in the platform and at the ground, emergency controls and safety systems.
2. Control labels, instructions, and warnings on the machine.
3. Rules of the employer and government regulations.
4. Use of approved fall protection device.
5. Enough knowledge of the mechanical operation of the machine to recognize a malfunction or potential malfunction.

6. The safest means to operate the machine where overhead obstructions, other moving equipment, and obstacles, depressions, holes, drop-offs.
7. Means to avoid the hazards of unprotected electrical conductors.
8. Specific job requirements or machine application.

Training Supervision

Training must be done under the supervision of a qualified person in an open area free of obstructions until the trainee has developed the ability to safely control and operate the machine.

Operator Responsibility

The operator must be instructed that he/she has the responsibility and authority to shut down the machine in case of a malfunction or other unsafe condition of either the machine or the job site.

2.2 PREPARATION, INSPECTION, AND MAINTENANCE

The following table covers the periodic machine inspections and maintenance required by JLG Industries, Inc. Consult local regulations for further requirements for aerial work platforms. The frequency of inspections and maintenance must be increased as necessary when the machine is used in a harsh or hostile environment, if the machine is used with increased frequency, or if the machine is used in a severe manner.

NOTICE

JLG INDUSTRIES, INC. RECOGNIZES A FACTORY-TRAINED SERVICE TECHNICIAN AS A PERSON WHO HAS SUCCESSFULLY COMPLETED THE JLG SERVICE TRAINING SCHOOL FOR THE SPECIFIC JLG PRODUCT MODEL.

SECTION 2 - USER RESPONSIBILITIES, MACHINE PREPARATION, AND INSPECTION

Table 2-1. Inspection and Maintenance Table

Type	Frequency	Primary Responsibility	Service Qualification	Reference
Pre-Start Inspection	Before using each day; or whenever there's an Operator change.	User or Operator	User or Operator	Operator and Safety Manual
Pre-Delivery Inspection (See Note)	Before each sale, lease, or rental delivery.	Owner, Dealer, or User	Qualified JLG Mechanic	Service and Maintenance Manual and applicable JLG inspection form
Frequent Inspection (See Note)	In service for 3 months or 150 hours, whichever comes first; or Out of service for a period of more than 3 months; or Purchased used.	Owner, Dealer, or User	Qualified JLG Mechanic	Service and Maintenance Manual and applicable JLG inspection form
Annual Machine Inspection (See Note)	Annually, no later than 13 months from the date of prior inspection.	Owner, Dealer, or User	Factory-Trained Service Technician (Recommended)	Service and Maintenance Manual and applicable JLG inspection form
Preventative Maintenance	At intervals as specified in the Service and Maintenance Manual.	Owner, Dealer, or User	Qualified JLG Mechanic	Service and Maintenance Manual
NOTE: Inspection forms are available from JLG. Use the Service and Maintenance Manual to perform inspections.				

Pre-Start Inspection

The Pre-Start Inspection should include each of the following:

1. **Cleanliness** – Check all surfaces for leakage (oil, fuel, or battery fluid) or foreign objects. Report any leakage to the proper maintenance personnel.
2. **Structure** - Inspect the machine structure for dents, damage, weld or parent metal cracks or other discrepancies.

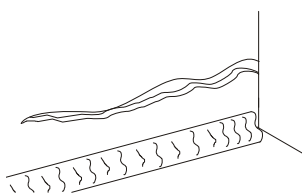

Parent Metal Crack

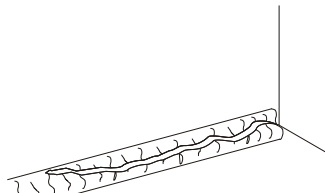

Weld Crack

3. **Decals and Placards** – Check all for cleanliness and legibility. Make sure none of the decals and placards are missing. Make sure all illegible decals and placards are cleaned or replaced.

4. **Operation and Safety Manuals** – Make sure a copy of the Operator and Safety Manual, AEM Safety Manual (ANSI markets only), and ANSI Manual of Responsibilities (ANSI markets only) is enclosed in the weather resistant storage container.
5. **“Walk-Around” Inspection** – Refer to Figure 2-2.
6. **Battery** – Charge as required.
7. **Hydraulic Oil** – Check the hydraulic oil level. Ensure hydraulic oil is added as required.
8. **Accessories/Attachments** - Reference the Operator and Safety Manual of each attachment or accessory installed upon the machine for specific inspection, operation, and maintenance instructions.

SECTION 2 - USER RESPONSIBILITIES, MACHINE PREPARATION, AND INSPECTION

9. **Function Check** – Once the “Walk-Around” Inspection is complete, perform a functional check of all systems in an area free of overhead and ground level obstructions. Refer to Section 4 for more specific operating instructions.

WARNING

IF THE MACHINE DOES NOT OPERATE PROPERLY, TURN OFF THE MACHINE IMMEDIATELY! REPORT THE PROBLEM TO THE PROPER MAINTENANCE PERSONNEL. DO NOT OPERATE THE MACHINE UNTIL IT IS DECLARED SAFE FOR OPERATION.

Function Check

Perform the Function Check as follows:

1. From the ground control console with no load in the platform:
 - a. Check that all guards protecting the switches or locks are in place;
 - b. Operate all functions and ensure proper operation;
 - c. Ensure that all machine functions are disabled when the Emergency Stop Button is pushed in.
 - d. Ensure all boom functions stop when the function enable switch is released.

SECTION 2 - USER RESPONSIBILITIES, MACHINE PREPARATION, AND INSPECTION

2. From the platform control console:
 - a. Ensure that the control console is firmly secured in the proper location;
 - b. Check that all guards protecting the switches or locks are in place;
 - c. Operate all functions and ensure proper operation;
 - d. Ensure that all machine functions are disabled when the Emergency Stop Button is pushed in.
 - e. Ensure that all machine functions stop when the footswitch is released.
3. With the platform in the stowed position:
 - a. Drive the machine on a grade, not to exceed the rated gradeability, and stop to ensure the brakes hold;
 - b. Check that the tilt indicator is illuminated to ensure proper operation.
4. Swing the boom over either of the rear tires and ensure that the Drive Orientation indicator illuminates and that the Drive Orientation Override switch must be used for the drive function to operate.

SECTION 2 - USER RESPONSIBILITIES, MACHINE PREPARATION, AND INSPECTION

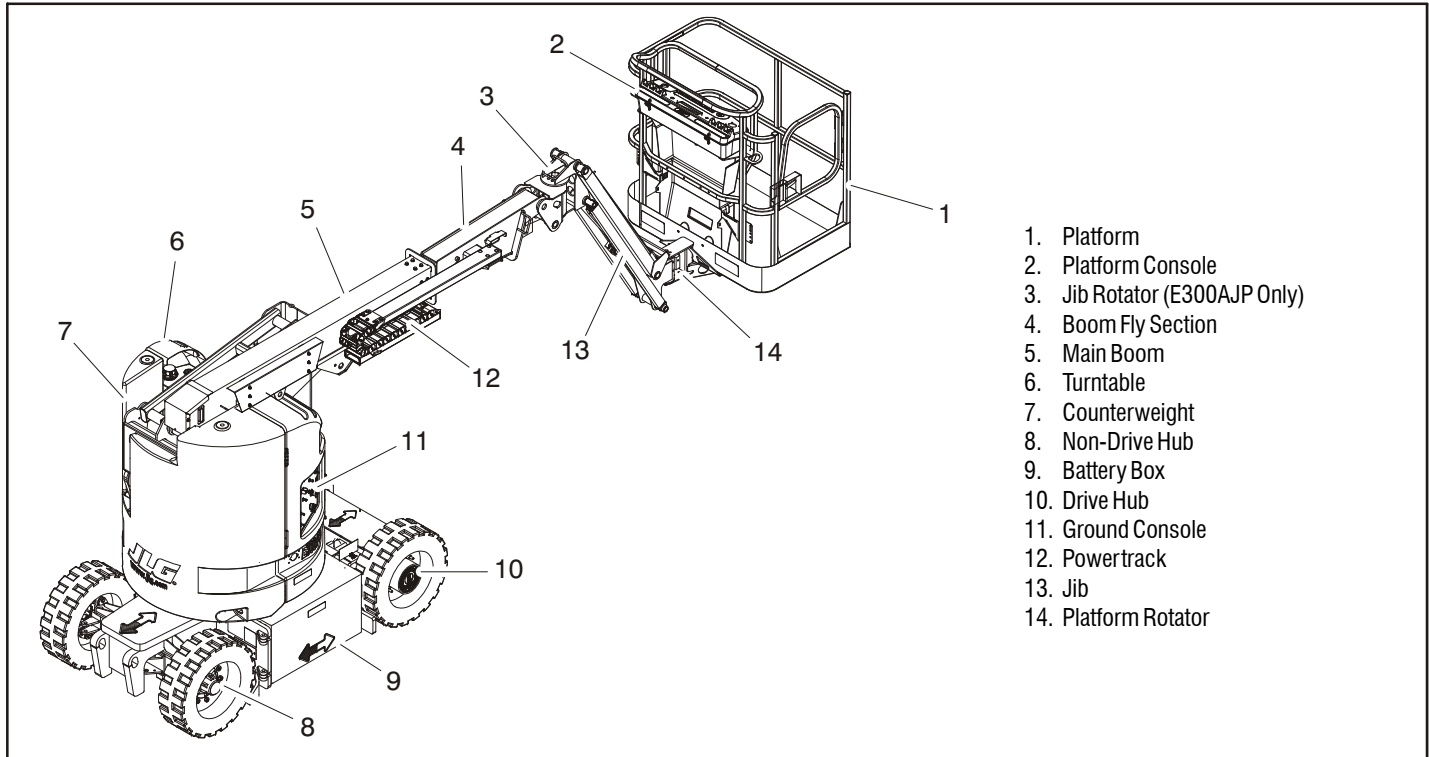

Figure 2-1. Basic Nomenclature

SECTION 2 - USER RESPONSIBILITIES, MACHINE PREPARATION, AND INSPECTION

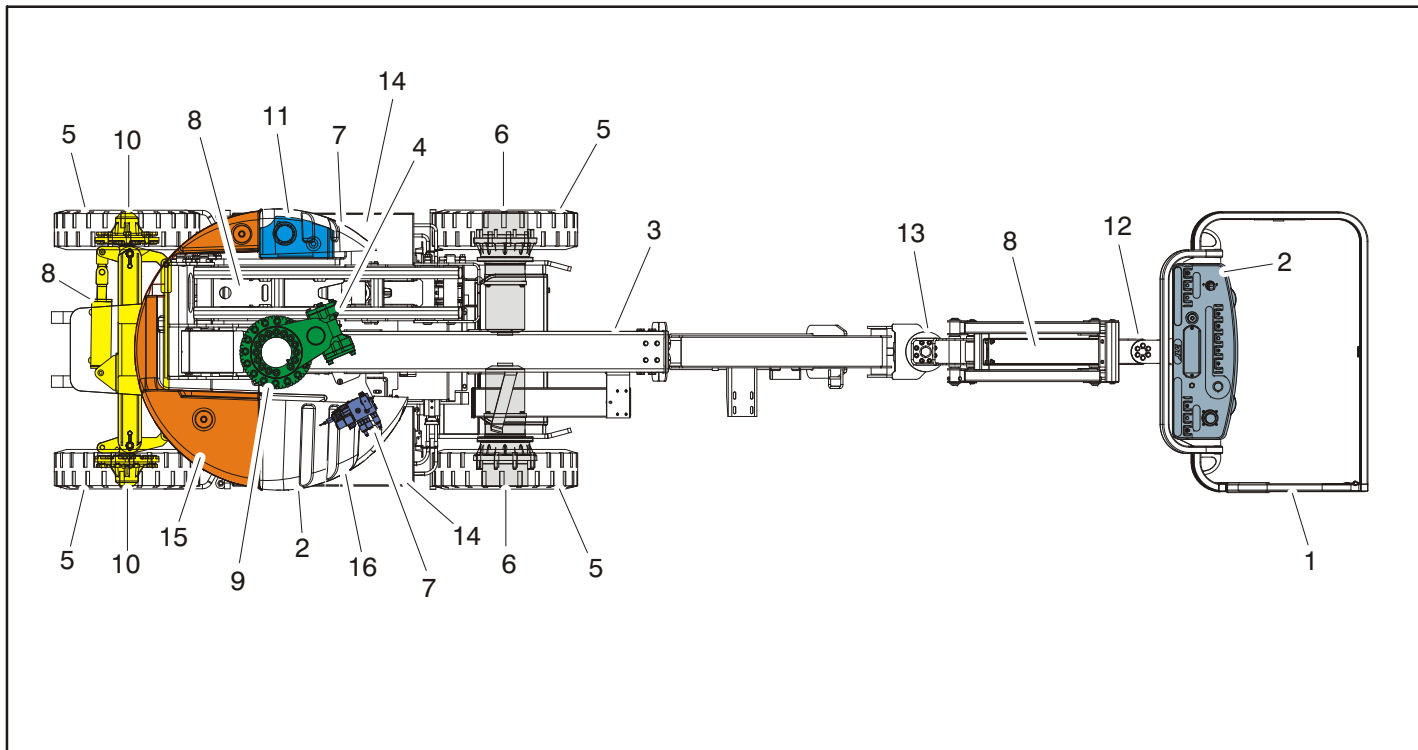

Figure 2-2. Daily Walk-Around Inspection - Sheet 1 of 3

SECTION 2 - USER RESPONSIBILITIES, MACHINE PREPARATION, AND INSPECTION

General

Begin the "Walk-Around Inspection" at Item 1, as noted on the diagram. Continue checking each item in sequence for the conditions listed in the following checklist.

WARNING

TO AVOID POSSIBLE INJURY, BE SURE MACHINE POWER IS OFF.

DO NOT OPERATE MACHINE UNTIL ALL MALFUNCTIONS HAVE BEEN CORRECTED.

***INSPECTION NOTE:** On all components, make sure there are no loose or missing parts, that they are securely fastened, and no visible damage, leaks or excessive wear exists in addition to any other criteria mentioned.*

- 1. Platform Assembly and Gate** - Footswitch works properly, not modified, disabled or blocked. Latch and hinges in working condition.
- 2. Platform & Ground Control Consoles** - Switches and levers return to neutral, decals/placards secure and legible, control markings legible.
- 3. Boom Sections/Uprights/Turntable** - See Inspection Note.
- 4. Swing Motor and Worm Gear** - No evidence of damage.
- 5. Wheel/Tire Assemblies** - Properly secured, no missing lug nuts. Inspect for worn tread, cuts, tears or other discrepancies. Inspect wheels for damage and corrosion.
- 6. Drive Motor, Brake, and Hub** - No evidence of leakage.
- 7. Hood Assemblies** - See Inspection Note.
- 8. All Hydraulic Cylinders** - No visible damage; pivot pins and hydraulic hoses undamaged, not leaking.
- 9. Turntable Bearing** - Evidence of proper lubrication. No evidence of loose bolts or looseness between bearing and machine.
- 10. Tie Rod Ends and Steering Spindles** - See Inspection Note.

Figure 2-3. Daily Walk-Around Inspection - Sheet 2 of 3

SECTION 2 - USER RESPONSIBILITIES, MACHINE PREPARATION, AND INSPECTION

- 11. **Hydraulic Pump and Reservoir** - See Inspection Note.
- 12. **Platform Rotator** - See Inspection Note.
- 13. **Jib Rotator** - See Inspection Note.
- 14. **Battery Compartment** - Batteries have proper electrolyte level; cables tight; see Inspection Note.
- 15. **Counterweight** - See Inspection Note.
- 16. **Manual Descent** - See Inspection Note.

Figure 2-4. Daily Walk-Around Inspection - Sheet 3 of 3

SECTION 3. MACHINE CONTROLS AND INDICATORS

3.1 GENERAL

NOTICE

THE MANUFACTURER HAS NO DIRECT CONTROL OVER MACHINE APPLICATION AND OPERATION. THE USER AND OPERATOR ARE RESPONSIBLE FOR CONFORMING WITH GOOD SAFETY PRACTICES.

This section provides the necessary information needed to understand control functions.

3.2 CONTROLS AND INDICATORS

NOTE: All machines are equipped with control panels that use symbols to indicate control functions. On ANSI machines refer to decal located on the control box guard in front of the control box or by the ground controls for these symbols and the corresponding functions.

NOTE: The indicator panels use different shaped symbols to alert the operator to different types of operational situations that could arise. The meaning of those symbols are explained below.



Indicates a potentially hazardous situation, which if not corrected, could result in serious injury or death. This indicator will be red.



Indicates an abnormal operating condition, which if not corrected, may result in machine interruption or damage. This indicator will be yellow.



Indicates important information regarding the operating condition, i.e. procedures essential for safe operation. This indicator will be green with the exception of the capacity indicator which will be green or yellow depending upon platform position.

SECTION 3 - MACHINE CONTROLS AND INDICATORS

WARNING

TO AVOID SERIOUS INJURY, DO NOT OPERATE MACHINE IF ANY CONTROL LEVERS OR TOGGLE SWITCHES CONTROLLING PLATFORM MOVEMENT DO NOT RETURN TO THE OFF POSITION WHEN RELEASED.

Ground Control Station

(See Figure 3-1. and Figure 3-2.)

NOTE: *When machine is shut down the Platform/Ground Select switch and Emergency Stop must be positioned to OFF.*

NOTE: *When Power/Emergency Stop Switch is in the on position and motor is not running, an alarm will sound, indicating power is on.*

NOTE: *The Function Enable switch must be held down in order to operate Boom Telescope, Lower Lift, Swing, Main Lift, Jib Lift, Platform Level Override, and Platform Rotate functions.*



1. Battery Charge Status

Three LED lights indicate charge status of battery. **Green**; indicates 100% charged. **Yellow**; indicates charger on. **Red**; indicates abnormal battery condition.

2. Function Enable

The enable switch must be held "DOWN" to enable all boom controls when the machine power is on.

3. Main Boom Lift

Provides raising/lowering of the main boom when positioning up or down.

4. Lower Boom Lift

Provides raising and lowering of the upright and lower booms.

5. Swing

Provides 350 degrees non-continuous turntable rotation. To activate SWING, position switch to LEFT or RIGHT.

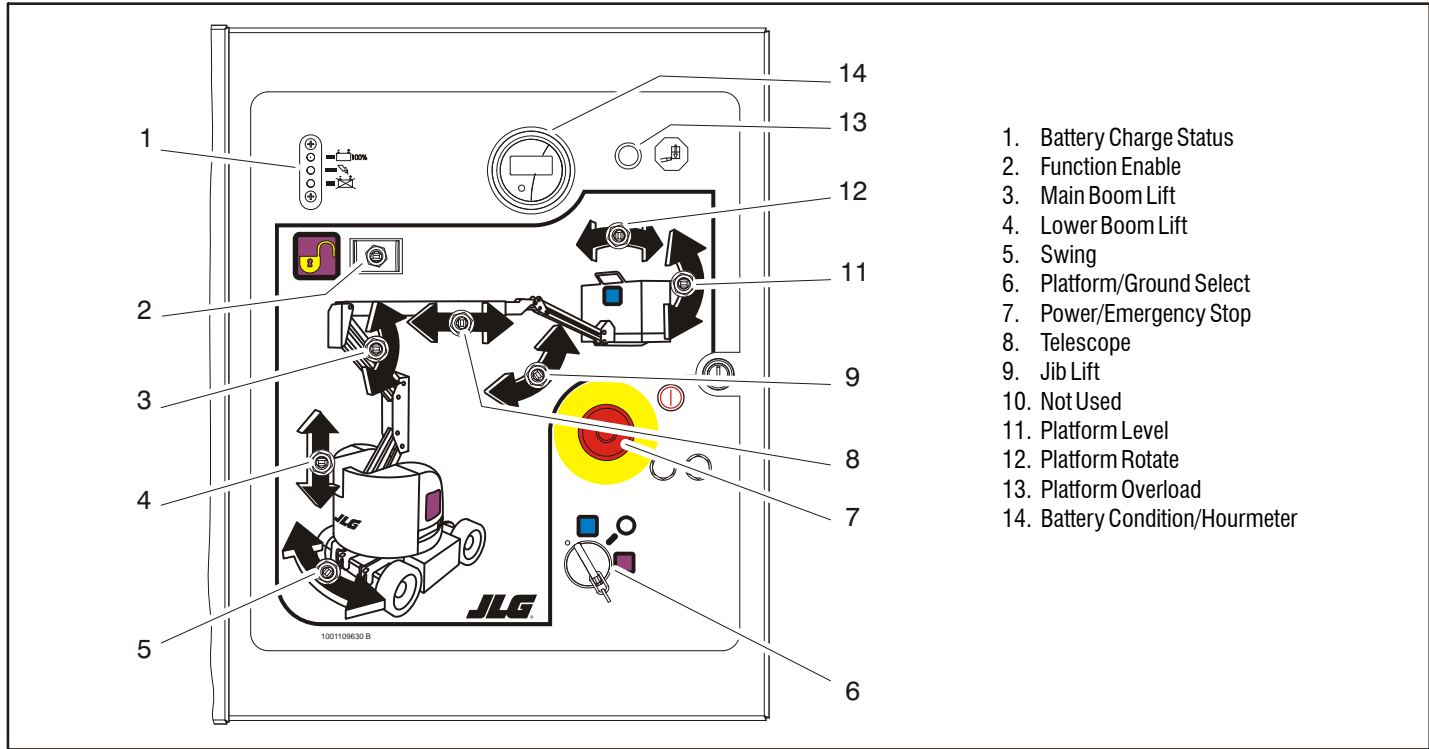

1. Battery Charge Status
2. Function Enable
3. Main Boom Lift
4. Lower Boom Lift
5. Swing
6. Platform/Ground Select
7. Power/Emergency Stop
8. Telescope
9. Jib Lift
10. Not Used
11. Platform Level
12. Platform Rotate
13. Platform Overload
14. Battery Condition/Hourmeter

Figure 3-1. Ground Control Station - E300AJ

SECTION 3 - MACHINE CONTROLS AND INDICATORS

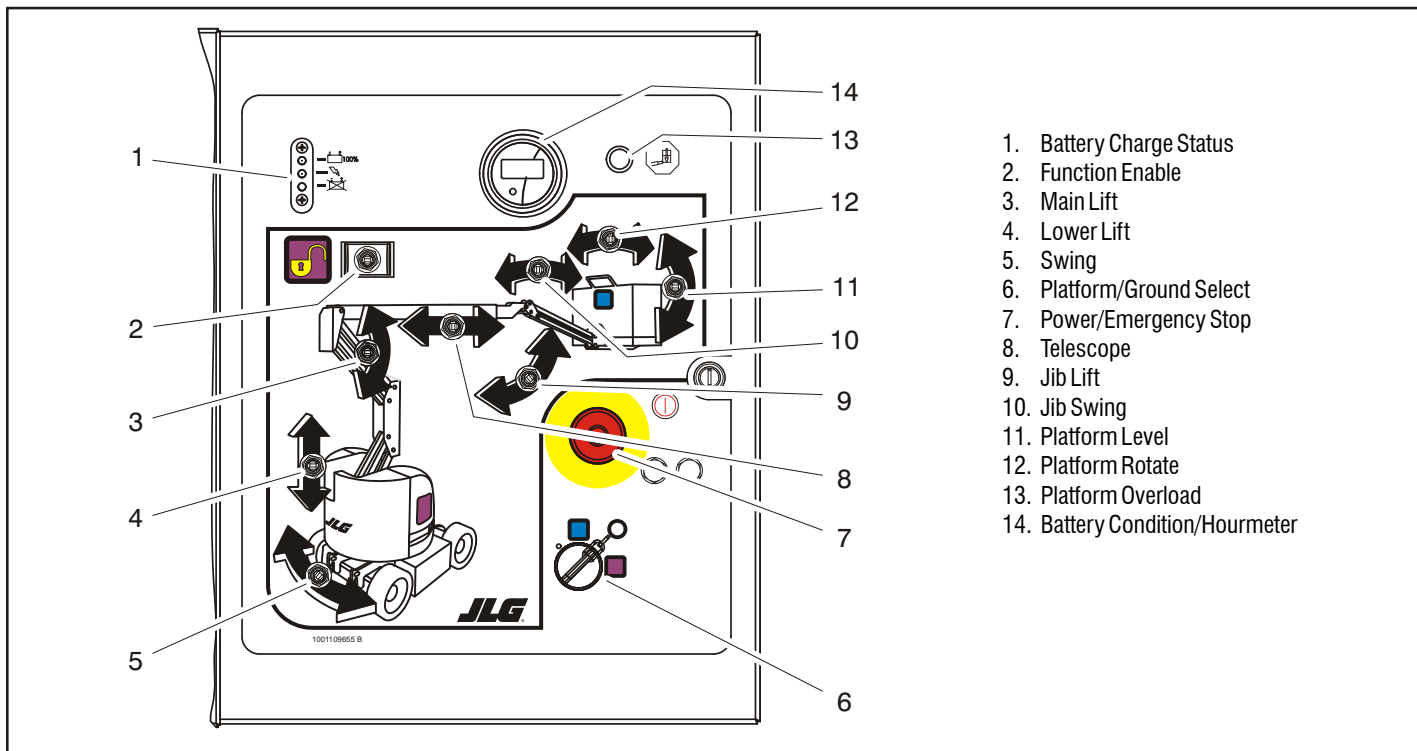

Figure 3-2. Ground Control Station - E300AJP

NOTE: When the Platform/Ground Select Switch is in the center position, power is shut off to the controls at both operating stations. Remove the key to prevent the controls from being actuated. The key is removable in the platform position on CE specification machines. The key must be available to ground personnel in the event of an emergency.

6. Platform/Ground Select Switch

The three position, key operated switch supplies power to the platform control console when positioned to PLATFORM. With the switch key turned to the GROUND position, power is shut off to platform and only ground controls are operable.



WHEN THE MACHINE IS SHUT DOWN THE POWER/EMERGENCY STOP SWITCH MUST BE POSITIONED TO THE OFF POSITION TO PREVENT DRAINING THE BATTERIES.

7. Power/Emergency Stop Switch

A two-position red mushroom shaped switch supplies power to PLATFORM/GROUND SELECT switch when pulled out (on). When pushed in (off), power is shut off to the PLATFORM/GROUND SELECT switch.

8. Telescope Control

Provides extension and retraction of the boom.

SECTION 3 - MACHINE CONTROLS AND INDICATORS

9. Jib Lift

Provides raising and lowering of the jib.

10. Jib Swing

Allows swinging of the jib.

⚠ WARNING

ONLY USE THE PLATFORM LEVELING OVERRIDE FUNCTION FOR SLIGHT LEVELING OF THE PLATFORM. INCORRECT USE COULD CAUSE THE LOAD/OCCUPANTS TO SHIFT OR FALL. FAILURE TO DO SO COULD RESULT IN DEATH OR SERIOUS INJURY.

11. Platform Leveling Override

A three position switch allows the operator to adjust the automatic self leveling system. This switch is used to adjust platform level in situations such as ascending/descending a grade.

12. Platform Rotate

Provides rotation of the platform.

13. Platform Overload (If equipped)

Indicates the platform has been overloaded.

14. Battery Indicator and Hourmeter

The battery indicator displays the present charge of the batteries. The hourmeter counts the amount of machine operating time, up to 9,999.9 hours, and cannot be reset.

Platform Station

(See Figure 3-2., Platform Control Console)

WARNING

TO AVOID SERIOUS INJURY, DO NOT OPERATE MACHINE IF ANY CONTROL LEVERS OR TOGGLE SWITCHES CONTROLLING PLATFORM MOVEMENT DO NOT RETURN TO THE OFF OR NEUTRAL POSITION WHEN RELEASED.

1. Posi-Track

When one wheel is slipping and the machine is not descending a grade, automatic traction control will provide added torque to both drive wheels. While this function is automatic, it may also be manually engaged by moving the toggle switch to the forward position. Posi-trac will be engaged for approximately 20 seconds.

WARNING

ONLY USE THE PLATFORM LEVELING OVERRIDE FUNCTION FOR SLIGHT LEVELING OF THE PLATFORM. INCORRECT USE COULD CAUSE THE LOAD/OCCUPANTS TO SHIFT OR FALL. FAILURE TO DO SO COULD RESULT IN DEATH OR SERIOUS INJURY.

2. Platform Leveling Override

A three position switch allows the operator to adjust the automatic self leveling system. This switch is used to adjust platform level in situations such as ascending/descending a grade.

3. Horn

A push-type HORN switch supplies electrical power to an audible warning device when pressed.

4. Power/Emergency Stop Switch

A two-position red mushroom shaped switch furnishes power to PLATFORM Controls when pulled out (on). When pushed in (off), power is shut off to the platform functions.

SECTION 3 - MACHINE CONTROLS AND INDICATORS

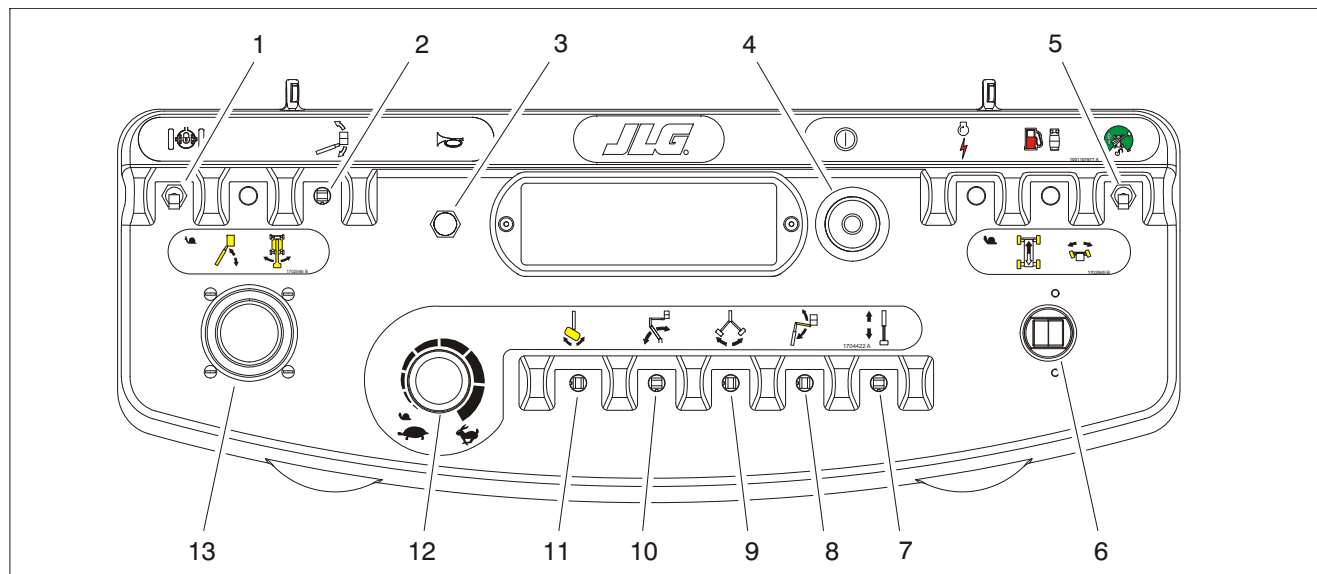

- | | | |
|-------------------------------|----------------|---------------------|
| 1. Posi-Track | 6. Drive/Steer | 10. Lower Boom Lift |
| 2. Platform Leveling Override | 7. Telescope | 11. Platform Rotate |
| 3. Horn | 8. Jib | 12. Function Speed |
| 4. Power/Emergency Stop | 9. Jib Swing | 13. Main Lift/Swing |
| 5. Drive Orientation Override | | |

Figure 3-2. Platform Control Console

SECTION 3 - MACHINE CONTROLS AND INDICATORS

5. Drive Orientation Override

When the boom is swung over the rear tires or further in either direction, the Drive Orientation indicator will illuminate when the drive function is selected. Push and release the switch, and within 3 seconds move the Drive/Steer control to activate drive or steer. Before driving, locate the black/white orientation arrows on both the chassis and the platform controls. Move the drive controls in a direction matching the directional arrows.

NOTE: *To operate the Drive joystick, pull up on the locking ring below the handle.*

NOTE: *The Drive joystick is spring loaded and will automatically return to neutral (off) position when released.*

6. Drive/Steer

Push forward to drive forward, pull back to drive in reverse. Steering is accomplished via a thumb-activated rocker switch on the end of the steer handle.

NOTE: *When boom is positioned above horizontal and Posi-Track engaged or Function speed are positioned to high, high function speeds are automatically cut out and the machine continues to operate at a lower speed.*

7. Telescope

Provides extension and retraction of the main boom.

8. Jib

Provides for raising or lowering of the jib by positioning up/down.

9. Jib Swing (If equipped)

Provides jib swing right or left.

10. Lower Boom Lift

Provides for raising and lowering of Upright when positioned to UP or DOWN.

11. Platform Rotate

Provides rotation of the platform when positioned to the right or left.

SECTION 3 - MACHINE CONTROLS AND INDICATORS

12. Function Speed Control

Adjusts speed of Boom and Swing Functions. Rotate counterclockwise for slower speed and clockwise for faster speed. To adjust Drive, Swing, and Main Boom Lift to creep, turn knob fully counterclockwise until it clicks.

NOTE: To operate the Main Boom Lift/Swing joystick, pull up on the locking ring below the handle.

NOTE: The Main Boom Lift/Swing joystick is spring loaded and will automatically return to neutral (off) position when released.

13. Main Lift/Swing Controller

Provides main lift and swing. Push forward to lift up, pull backward to boom down. Move right to swing right, move left to swing left. Moving the joystick activates switches to provide the functions selected. Proportional control of these functions can be attained by using the Function Speed knob.

Platform Control Indicator Panel

(See Figure 3-3., Platform Control Indicator Panel)

NOTE: *The platform control indicator panel uses different shaped symbols to alert the operator to different types of operational situations that could arise. The meaning of those symbols are explained below.*



Indicates a potentially hazardous situation, which if not corrected, could result in serious injury or death. This indicator will be red.



Indicates an abnormal operating condition, which if not corrected, may result in machine interruption or damage. This indicator will be yellow.



Indicates important information regarding the operating condition, i.e. procedures essential for safe operation. This indicator will be green with the exception of the capacity indicator which will be green or yellow depending upon platform position.

1. Tilt Alarm Warning Light and Alarm

Tilt Angle	Market
3°	CE & Australia
5°	ANSI & Japan

This red illuminator indicates that the chassis is on a slope. An alarm will also sound when the chassis is on a slope and the boom is above horizontal. If lit when boom is raised or extended, retract and lower to below horizontal then reposition machine so that it is level before continuing operation. If the boom is above horizontal and the machine is on a slope, the tilt alarm warning light will illuminate and an alarm will sound and CREEP is automatically activated.



IF TILT WARNING LIGHT IS ILLUMINATED WHEN BOOM IS RAISED OR EXTENDED, RETRACT AND LOWER TO BELOW HORIZONTAL THEN REPOSITION MACHINE SO THAT IT IS LEVEL BEFORE EXTENDING BOOM OR RAISING BOOM ABOVE HORIZONTAL.

SECTION 3 - MACHINE CONTROLS AND INDICATORS

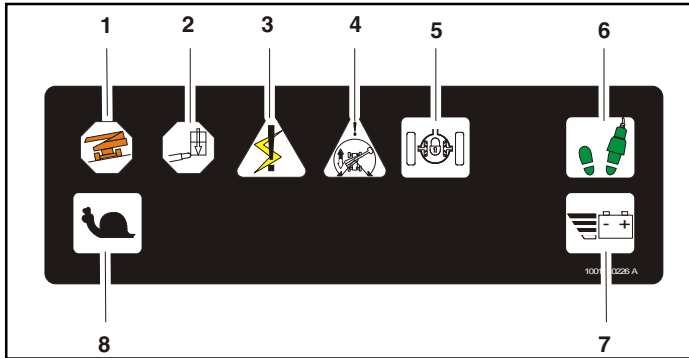

- | | |
|----------------------|----------------|
| 1. Tilt | 5. Posi-Track |
| 2. Platform Overload | 6. Enable |
| 3. System Distress | 7. Low Battery |
| 4. Drive Orientation | 8. Creep |

Figure 3-3. Platform Control Indicator Panel

2. Platform Overload (If equipped)

Indicates the platform has been overloaded.

3. System Distress Indicator

The system distress indicator lights to signify an electrical system fault.

The four likely causes of a system fault are:

- The seven second enable time has been allowed to lapse or a function was selected before depressing the footswitch. The system reads this condition as a fault, just as it would if the footswitch were jammed in the depressed position or a function switch were stuck in the on position. Re-depress the footswitch to power the controls and extinguish the light.
- The maximum power limit has been reached and the machine is not moving. This could happen when the machine is stuck or when attempting to travel over rough terrain or on steep grades which exceed the rated gradeability of the machine. This condition is comparable to stalling the engine by asking it to provide more power than it was designed to do.
- The batteries are nearly depleted, and should be charged very soon to prevent having the machine stop at an inconvenient place.
- There is some other fault in one of the circuits. Determine the cause by counting the flash code, a number of flashes followed by a pause followed by another number of flashes, and refer to the service manual.

4. Drive Orientation Indicator

When the boom is swung beyond the rear drive tires or further in either direction, the Drive Orientation indicator will illuminate when the drive function is selected. This is a signal for the operator to verify that the drive control is being operated in the proper direction (i.e. controls reversed situations).

5. Posi-Track Indicator

This indicator lights to show that posi-track is operating.

6. Enable Indicator/Footswitch

To operate any function, the footswitch must be depressed and the function selected within seven seconds. The enable indicator shows that the controls are enabled. If a function is not selected within seven seconds, or if a seven second lapse between ending one function and beginning the next function, the enable light will go out and the footswitch must be released and depressed again to enable the controls.

Releasing the footswitch removes power from all controls and applies the drive brakes.

WARNING

TO AVOID SERIOUS INJURY, DO NOT REMOVE, MODIFY OR DISABLE THE FOOTSWITCH BY BLOCKING OR ANY OTHER MEANS.

WARNING

FOOTSWITCH MUST BE ADJUSTED IF FUNCTIONS ACTIVATE WHEN SWITCH ONLY OPERATES WITHIN LAST 1/4" OF TRAVEL, TOP OR BOTTOM.

7. Low Battery Indicator

Indicates the batteries are low and need to be charged.

8. Creep Speed Indicator

When the Function Speed Control is turned to the creep position, the indicator acts as a reminder that all functions are set to the slowest speed.

SECTION 3 - MACHINE CONTROLS AND INDICATORS

 **NOTES:**

<hr/>	<hr/>
<hr/>	<hr/>
<hr/>	<hr/>
<hr/>	<hr/>
<hr/>	<hr/>
<hr/>	<hr/>
<hr/>	<hr/>
<hr/>	<hr/>
<hr/>	<hr/>
<hr/>	<hr/>
<hr/>	<hr/>
<hr/>	<hr/>
<hr/>	<hr/>
<hr/>	<hr/>
<hr/>	<hr/>
<hr/>	<hr/>
<hr/>	<hr/>
<hr/>	<hr/>
<hr/>	<hr/>
<hr/>	<hr/>
<hr/>	<hr/>
<hr/>	<hr/>

SECTION 4. MACHINE OPERATION

4.1 DESCRIPTION

This machine is a self-propelled hydraulic personnel lift equipped with a work platform on the end of an elevating and rotating boom.

The primary operator control station is in the platform. From this control station, the operator can drive and steer the machine in both forward and reverse directions. The operator can raise or lower the boom or swing the boom to the left or right. Standard boom swing is 350 degree non-continuous. The machine has a Ground Control Station which will override the Platform Control Station. Ground Controls operate Boom Lift and Swing, and are to be used in an emergency to lower the platform to the ground should the operator in the platform be unable to do so.

4.2 BOOM OPERATING CHARACTERISTICS AND LIMITATIONS

Stability

Machine stability is based on two (2) conditions which are called FORWARD and BACKWARD stability. The machine's position of least FORWARD stability is shown in Figure 4-1., and its position of least BACKWARD stability is shown in Figure 4-2. and Figure 4-3.

Capacities

Raising boom above horizontal with or without any load in platform, is based on the following criteria:

1. Machine is positioned on a smooth, firm and level surface.
2. Load is within manufacturers rated design capacity.
3. All machine systems are functioning properly.
4. Machine is as originally equipped from JLG.

WARNING

TO AVOID FORWARD OR BACKWARD TIPPING, DO NOT OVERLOAD MACHINE OR OPERATE THE MACHINE ON AN OUT-OF-LEVEL SURFACE.

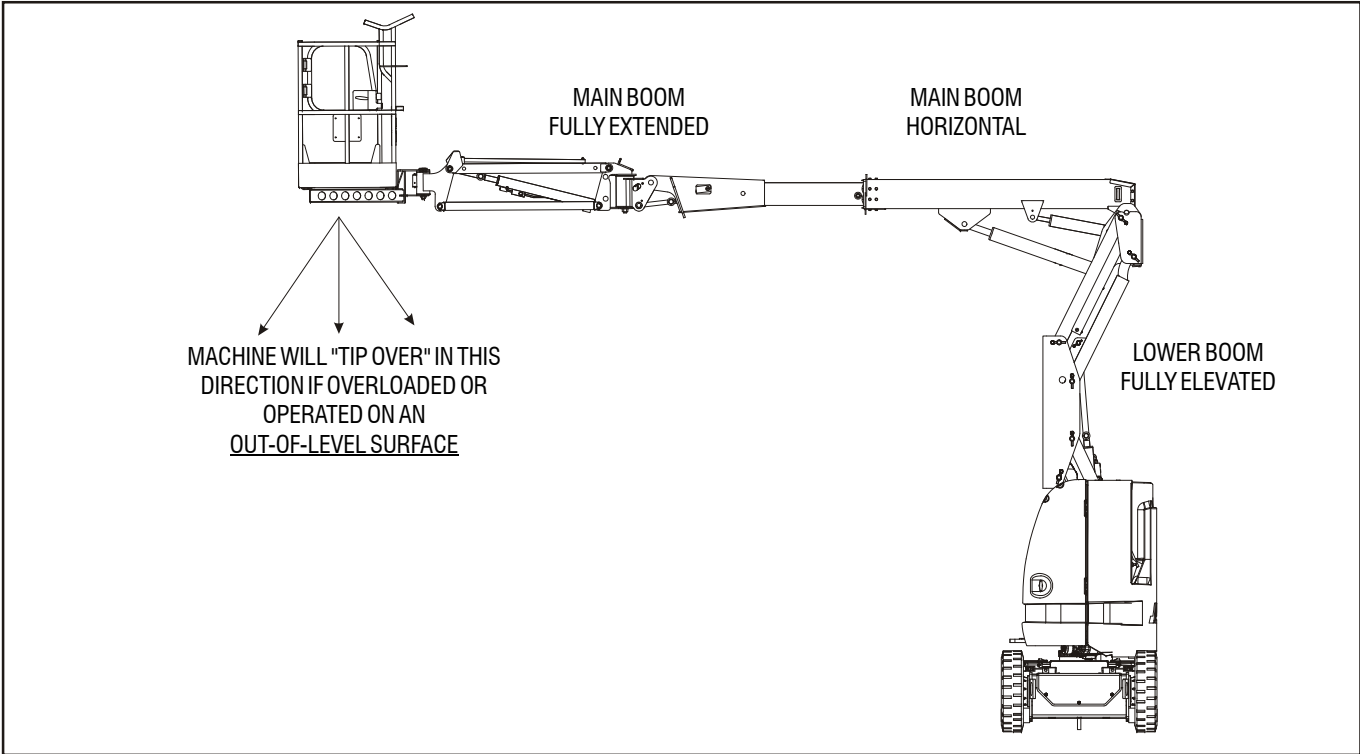

Figure 4-1. Position of Least Forward Stability

SECTION 4 - MACHINE OPERATION

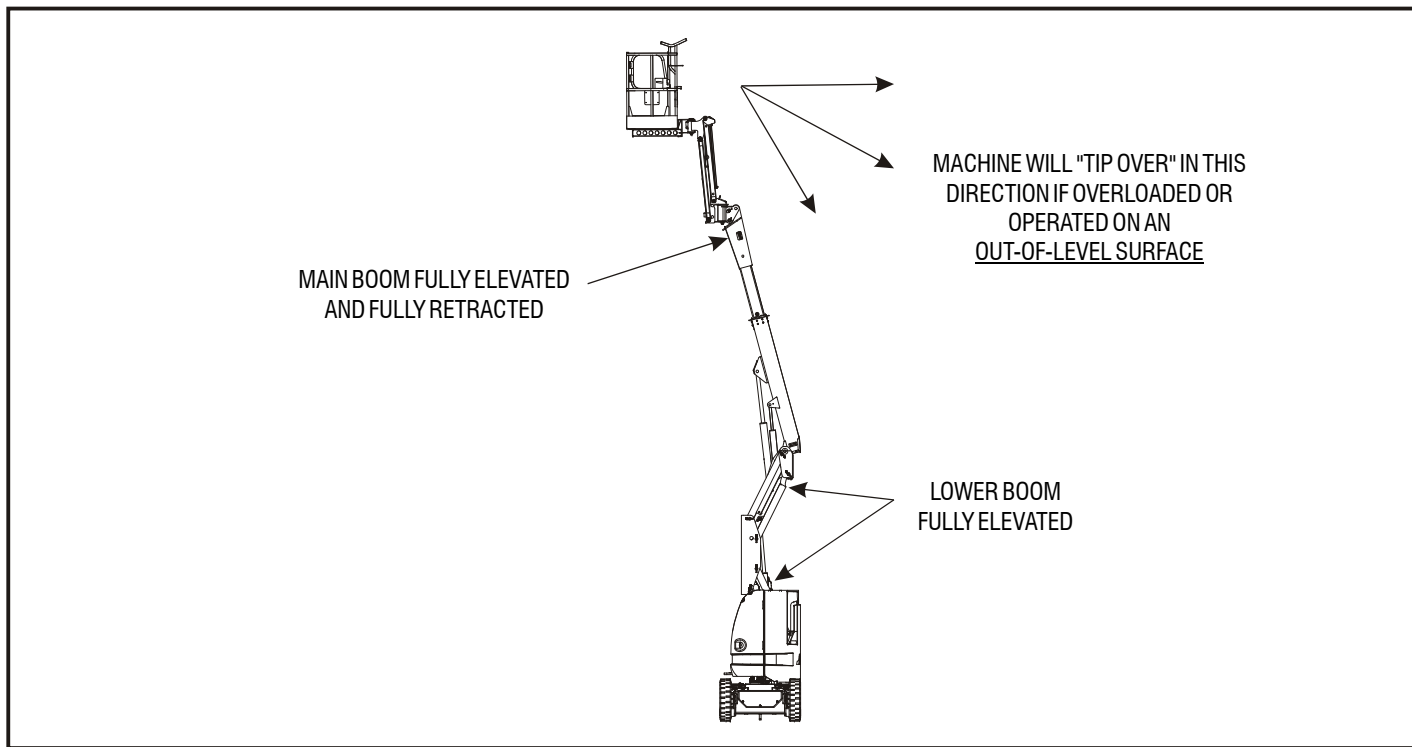

Figure 4-2. Position of Least Backward Stability - E300AJ

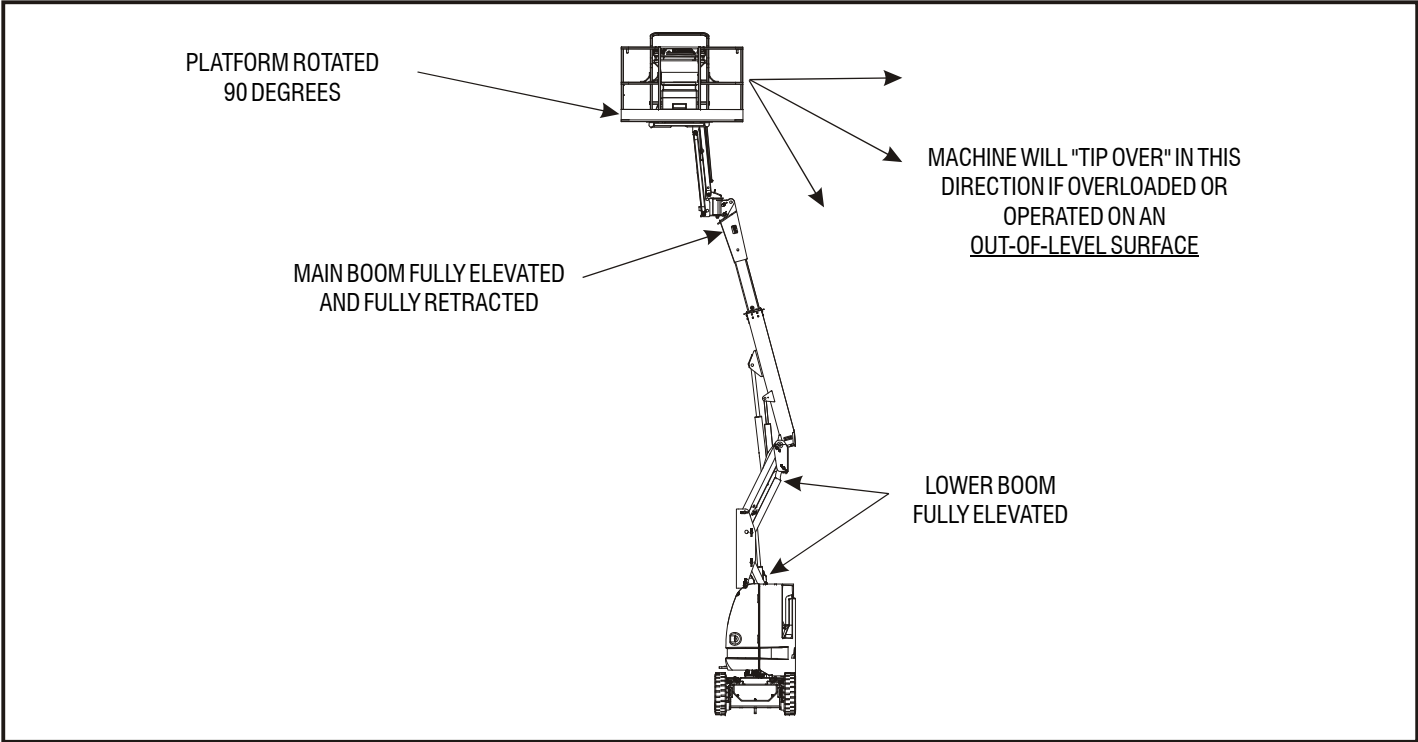

Figure 4-3. Position of Least Backward Stability - E300AJP

4.3 MOTOR OPERATION

Power/Emergency Stop Switch

This red, mushroom-shaped switch provides battery power to the Platform/Ground Select switch, when pulled out (on), for all machine functions. The switch should be pushed in (off) when recharging the batteries or parking the machine overnight.

Platform/Ground Select Switch

The Platform/Ground Select switch functions to direct battery power to the desired control station when the POWER/EMERGENCY STOP switch is pulled out (on). With the switch in the GROUND position, battery power is supplied to the ground control station. When the switch is in the PLATFORM position, battery power is supplied to the platform control station.

The key is removable in the platform position on CE machines. The key must be available to ground personnel in the event of an emergency.

Motor Activation

NOTICE

FOOTSWITCH MUST BE DEPRESSED PRIOR TO ACTIVATING ANY FUNCTION, OTHERWISE FUNCTION WILL NOT OPERATE.

The motor becomes activated and operates the desired function when the Emergency Stop switch is pulled out (on), the Platform/Ground select switch is in the appropriate position and the Footswitch is depressed.

⚠ CAUTION

IF A MOTOR MALFUNCTION NECESSITATES UNSCHEDULED SHUTDOWN, DETERMINE AND CORRECT THE CAUSE BEFORE RESUMING ANY OPERATION.

NOTICE

ALWAYS POSITION EMERGENCY STOP SWITCH TO THE 'OFF' POSITION (PUSHED IN) WHEN MACHINE IS NOT IN USE.

4.4 TRAVELING (DRIVING)

See Figure 4-4., Grade and Side Slopes

NOTE: Refer to the Operating Specifications table for Gradeability and Sideslope ratings.

All ratings for Gradeability and Sideslope are based upon the machine's boom being in the stowed position, fully lowered, and retracted.

⚠ WARNING

TO AVOID LOSS OF TRAVEL CONTROL OR "TIP OVER", DO NOT DRIVE MACHINE ON GRADES EXCEEDING THOSE SPECIFIED ON THE SERIAL NUMBER PLATE.

DO NOT DRIVE ON SIDESLOPES WHICH EXCEED 5 DEGREES.

USE EXTREME CAUTION WHEN DRIVING IN REVERSE AND AT ALL TIMES WHEN THE PLATFORM IS ELEVATED.

MATCH THE BLACK AND WHITE DIRECTION ARROWS ON BOTH PLATFORM CONTROL PANEL AND THE CHASSIS TO DETERMINE THE DIRECTION THE MACHINE WILL TRAVEL.

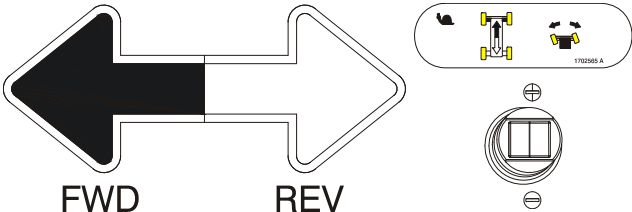

Traveling is limited by two factors:

- 1. Gradeability, which is the percent of grade of the incline the machine can climb.
- 2. Sideslope, which is the angle of the slope the machine can be driven across.

SECTION 4 - MACHINE OPERATION

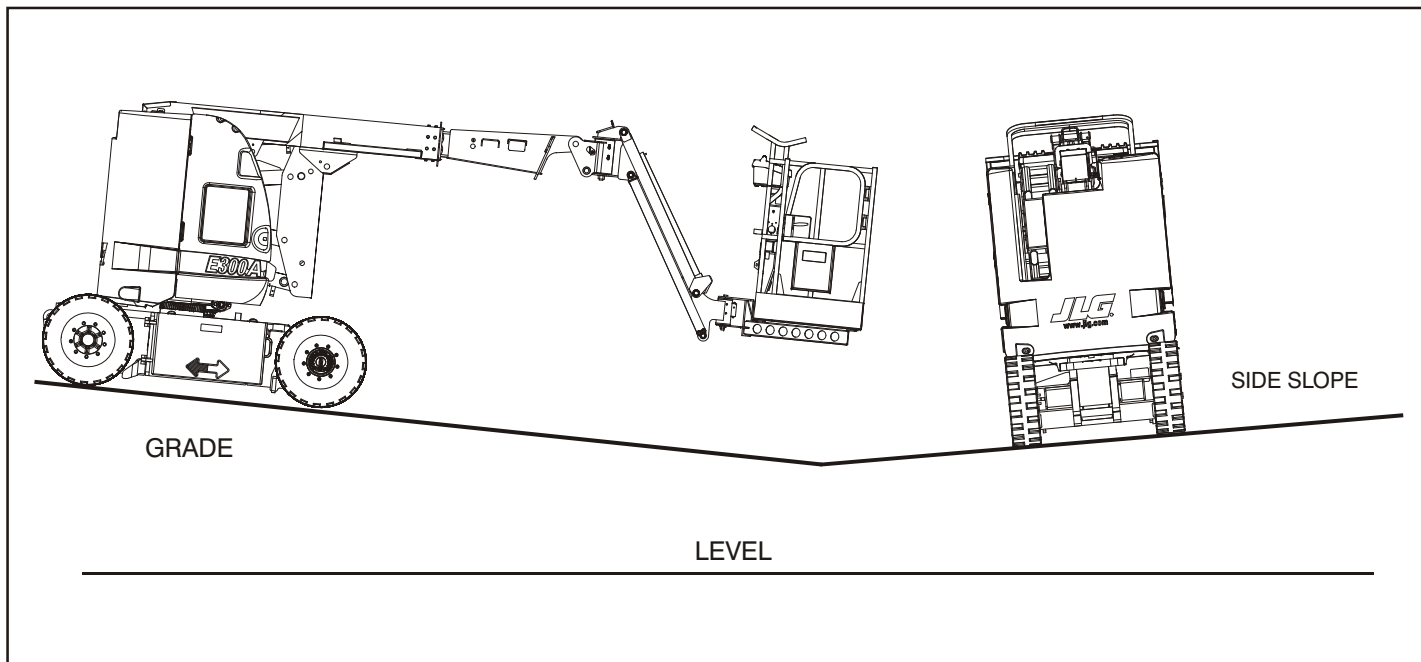

Figure 4-4. Grade and Side Slopes

Traveling Forward and Reverse

1. At Platform Controls, pull out Emergency Stop switch and activate footswitch.
2. Position Drive controller to FORWARD or REVERSE as desired.

This machine is equipped with a Drive Orientation Indicator. The yellow light on the platform control console indicates that the boom is swung beyond the rear drive tires and the machine may Drive/Steer in the opposite direction from the movement of the controls. If the indicator is illuminated, operate the Drive function in the following manner:

1. Match the black and white direction arrows on both platform control panel and the chassis to determine the direction the machine will travel.
2. Push and release the Drive Orientation Override switch. Within 3 seconds, slowly move the Drive control toward the arrow matching the intended direction of machine travel. The indicator light will flash during the 3 second interval until the drive function is selected.

4.5 STEERING

Position thumb switch on Drive/Steer controller to RIGHT for steering right, or to LEFT for steering left.

4.6 PLATFORM

WARNING

ONLY USE THE PLATFORM LEVELING OVERRIDE FUNCTION FOR SLIGHT LEVELING OF THE PLATFORM. INCORRECT USE COULD CAUSE THE LOAD/OCCUPANTS TO SHIFT OR FALL. FAILURE TO DO SO COULD RESULT IN DEATH OR SERIOUS INJURY.

Platform Level Adjustment

To manually Level Up or Down - Position the Platform/Level control switch Up or Down and hold until the desired platform position is obtained.

Platform Rotation

To rotate the platform to the left or right, use the Platform Rotate control switch to select the direction and hold until desired position is reached.

4.7 BOOM

WARNING

A RED TILT WARNING LIGHT IS LOCATED ON THE CONTROL CONSOLE WHICH LIGHTS WHEN THE CHASSIS IS ON AN EXCESSIVE SLOPE. DO NOT SWING OR RAISE BOOM ABOVE HORIZONTAL WHEN LIGHT IS LIT.

DO NOT DEPEND ON TILT ALARM AS A LEVEL INDICATOR FOR THE CHASSIS. TILT ALARM INDICATES CHASSIS IS ON AN EXCESSIVE SLOPE (5 DEGREE OR GREATER). CHASSIS MUST BE LEVEL BEFORE SWINGING, OR RAISING BOOM ABOVE HORIZONTAL OR DRIVING WITH THE BOOM ELEVATED.

TO AVOID TIP OVER IF RED TILT WARNING LIGHT LIGHTS WHEN BOOM IS RAISED ABOVE HORIZONTAL, LOWER PLATFORM TO GROUND LEVEL. THEN REPOSITION MACHINE SO THAT CHASSIS IS LEVEL BEFORE RAISING BOOM.

TRAVELING WITH BOOM BELOW HORIZONTAL IS PERMITTED ON GRADES AND SIDE SLOPES SPECIFIED ON SERIAL NAMEPLATE ON THE FRAME.

WARNING

TO AVOID SERIOUS INJURY, DO NOT OPERATE MACHINERY IF ANY CONTROL LEVER OR TOGGLE SWITCH CONTROLLING PLATFORM MOVEMENT DOES NOT RETURN TO THE 'OFF' OR NEUTRAL POSITION WHEN RELEASED.

CAUTION

TO AVOID A COLLISION AND INJURY IF PLATFORM DOES NOT STOP WHEN A CONTROL SWITCH OR LEVER IS RELEASED, REMOVE FOOT FROM FOOTSWITCH OR USE EMERGENCY STOP SWITCH TO STOP THE MACHINE.

Swinging the Boom

To swing boom, use Swing control to select Right or Left direction.

Raising and Lowering the Upper Boom

To raise or lower the Upper Boom, position Upper Boom Lift switch to Up or Down until desired height is reached.

4.8 FUNCTION SPEED CONTROL

This control affects the speed of boom functions and platform rotate Lift, Telescope, and Swing. When in the fully counterclockwise position, Drive is placed in creep speed.

4.9 SHUT DOWN AND PARK

NOTE: *When parking battery powered units overnight, batteries should be charged in accordance with instructions in Section 6 to ensure readiness for following workday.*

NOTE: *Electric machines are equipped with a static strap due to static electricity build-ups. Strap is located under rear of machine chassis.*

The procedures to shut down and park the machine are as follows:

1. Drive machine to a reasonably well protected area.
2. Ensure boom is lowered over rear drive axle.

SECTION 4 - MACHINE OPERATION

3. Shut down Emergency Stop at Platform Controls.
4. Shut down Emergency Stop at Ground Controls. Position Platform/Ground Select switch to center OFF.
5. If necessary, cover Platform Controls to protect instruction placards, warning decals, and operating controls from hostile environment.

4.10 LIFTING AND TIE DOWN

(See Figure 4-5.)

Lifting

1. Refer to the Serial Number Plate, refer to the Specifications section of this manual, or weigh the individual unit to find out the Gross Vehicle Weight.
2. Place the boom in the stowed position.
3. Remove all loose items from the machine.
4. Properly adjust the rigging to prevent damage to the machine and so the machine remains level.

Tie Down

NOTICE

WHEN TRANSPORTING THE MACHINE, THE BOOM MUST BE FULLY LOWERED INTO THE BOOM REST.

1. Place the boom in the stowed position.
2. Remove all loose items from the machine.
3. Secure the chassis and the platform using straps or chains of adequate strength.

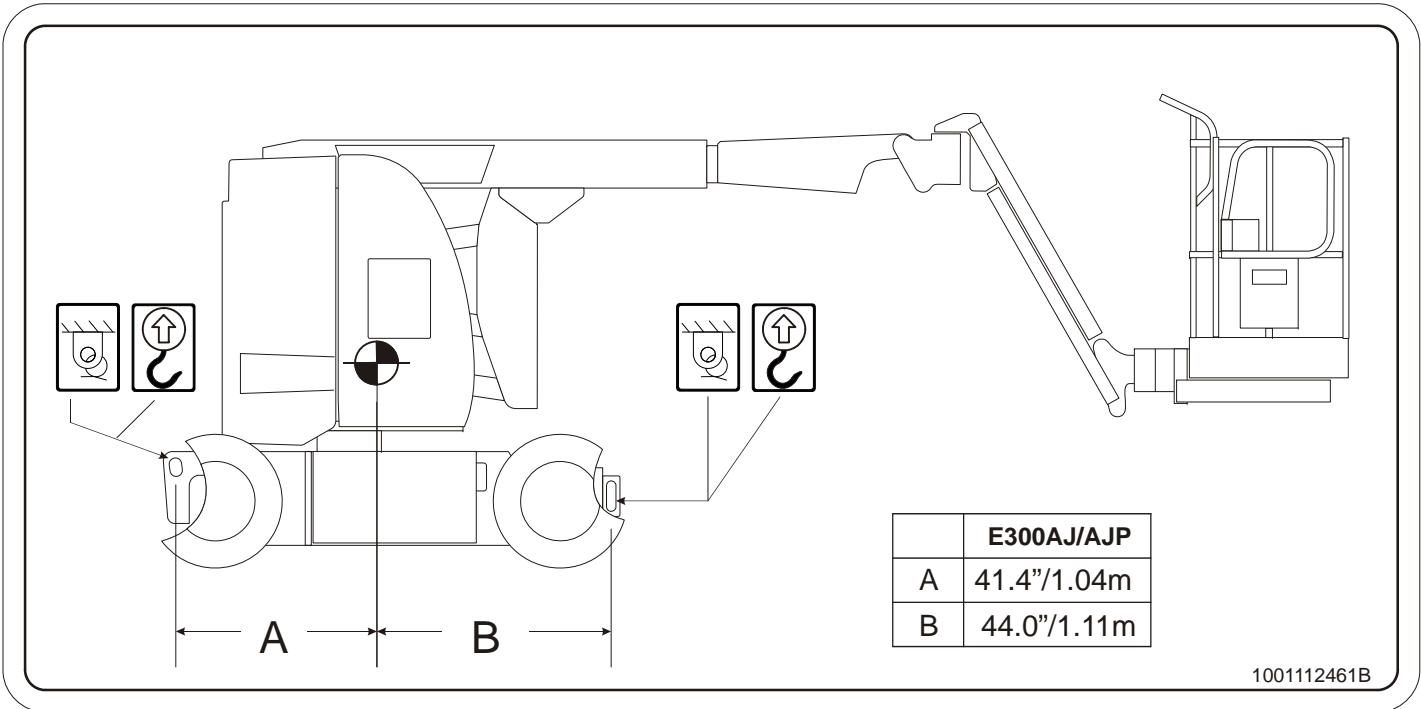

1001112461B

Figure 4-5. Lifting and Tie Down Chart

SECTION 4 - MACHINE OPERATION

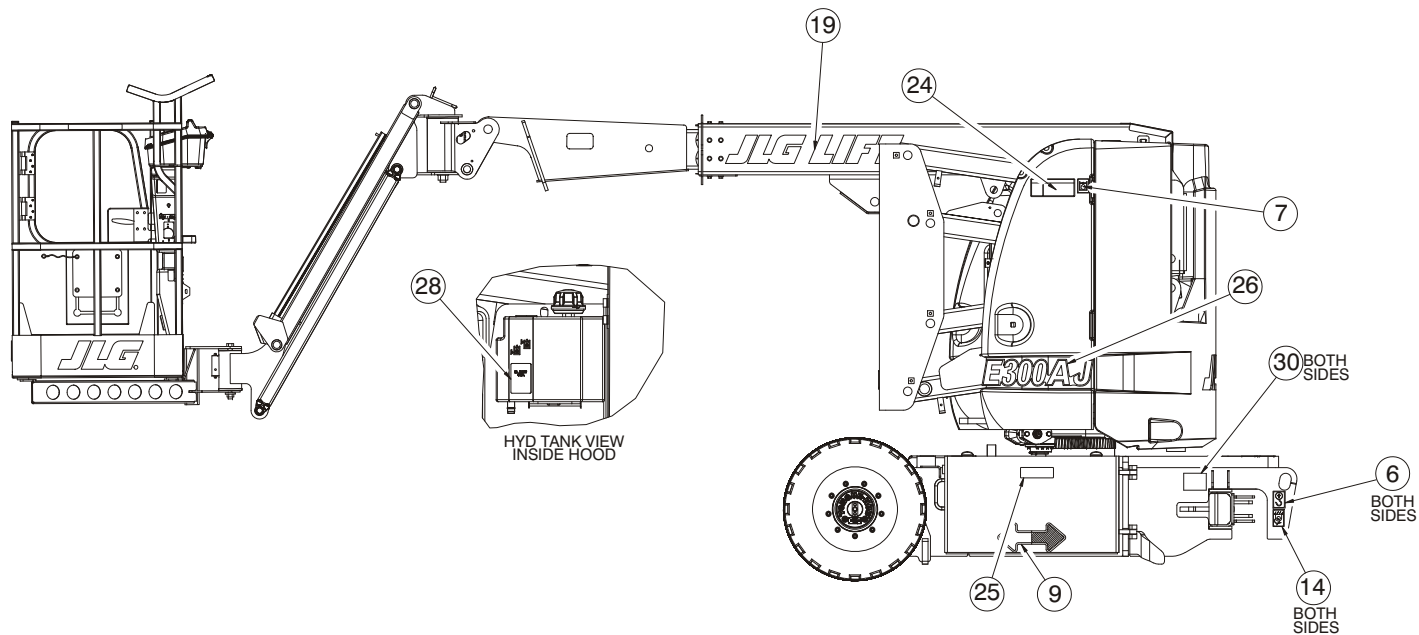

Figure 4-6. Decal Location Sheet 1 of 5

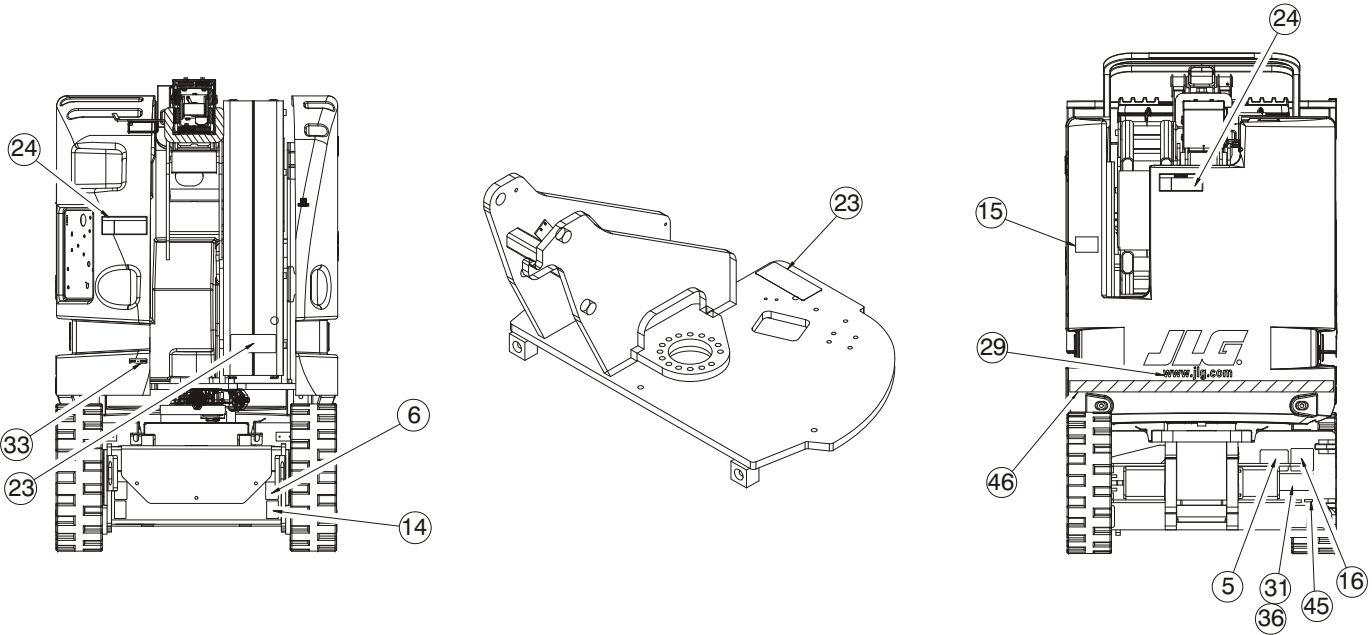

Figure 4-7. Decal Location Sheet 2 of 5

SECTION 4 - MACHINE OPERATION

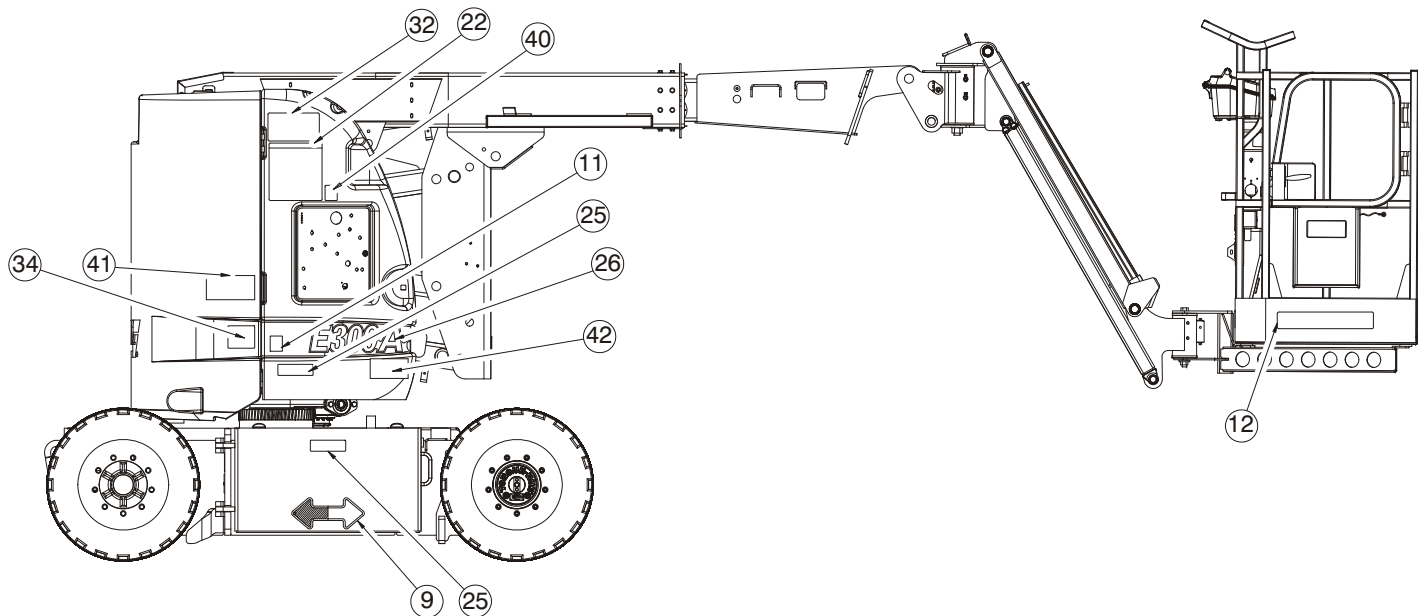

Figure 4-8. Decal Location Sheet 3 of 5

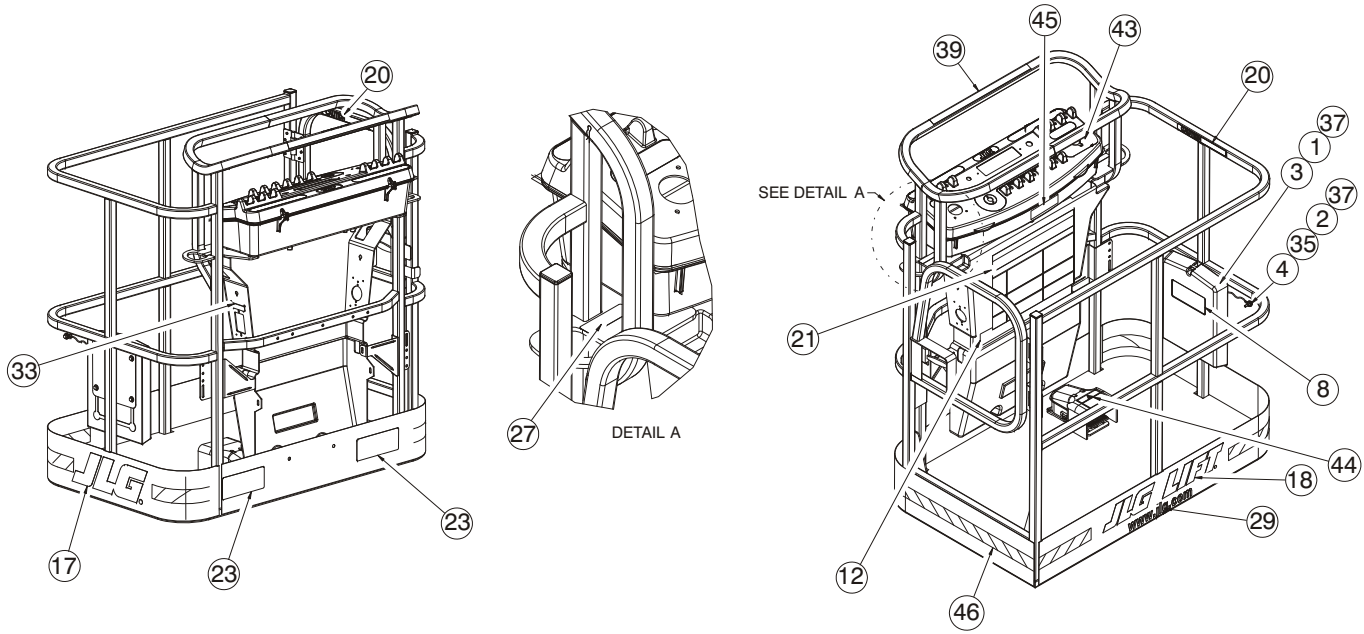

Figure 4-9. Decal Location Sheet 4 of 5

SECTION 4 - MACHINE OPERATION

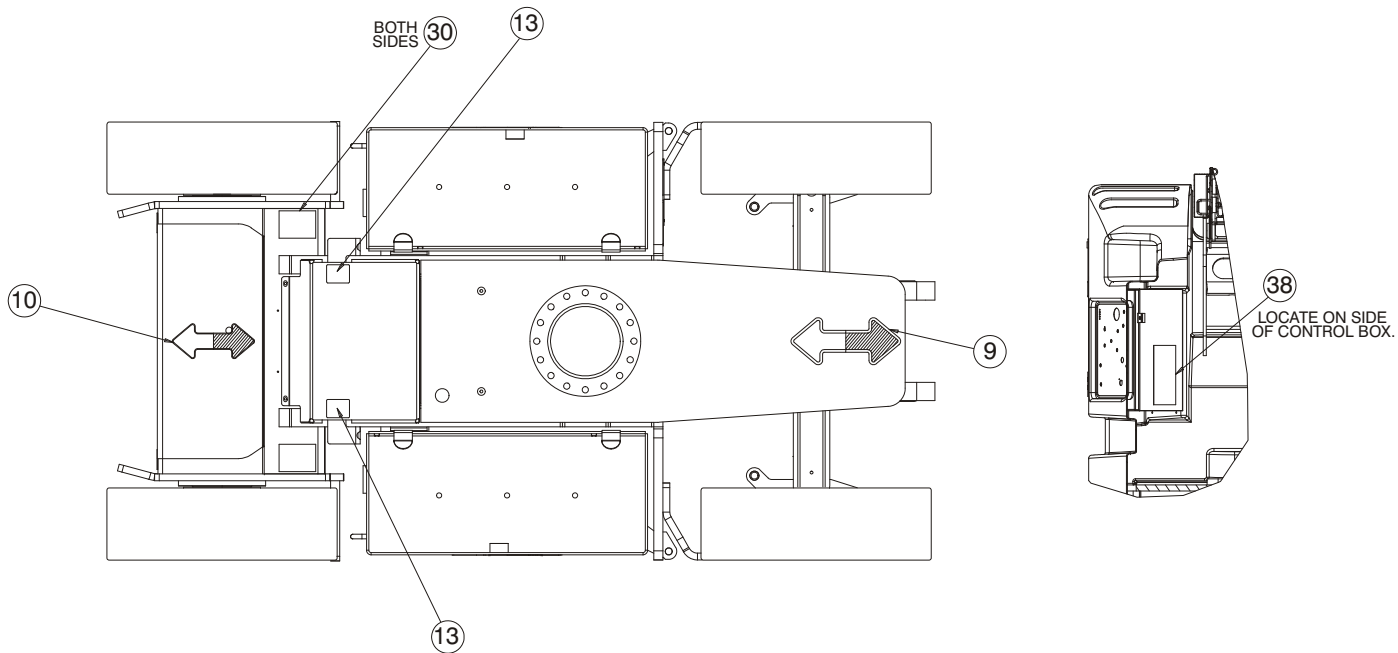

Figure 4-10. Decal Location Sheet 5 of 5

SECTION 4 - MACHINE OPERATION

Item #	ANSI 1001109493-B	CE/Australia 1001110824-C	Japan 1001110825-B	Korea 1001110827-B	Spanish 1001110828-B	French 1001110829-C	Chinese 1001110830-B	Portuguese 1001110831-B
1	--	--	--	--	--	--	--	--
2	--	--	--	--	--	--	--	--
3	--	--	--	--	--	--	--	--
4	--	--	--	--	--	--	--	--
5	1700584	1700584	1700584	1700584	1700584	1700584	1700584	1700584
6	1701500	1701500	1701500	1701500	1701500	1701500	1701500	1701500
7	1701504	1701504	1701504	1701504	1701504	1701504	1701504	1701504
8	1701509	1701509	1701509	1701509	1701509	1701509	1701509	1701509
9	1701529	1701529	1701529	1701529	1701529	1701529	1701529	1701529
10	1701642	1701642	1701642	1701642	1701642	1701642	1701642	1701642
11	1701644	1701644	1701644	1701644	1701644	1701644	1701644	1701644
12	1701645	1705978	1707059	1707058	1707056	1707055	1707060	1707134
13	1702155	1702155	1702155	1702155	1702155	1702155	1702155	1702155
14	1702300	1702300	1702300	1702300	1702300	1702300	1702300	1702300
15	1702391	1701517	1001113166	1001113509	1001113171	1001113169	1001113168	1001113170
16	1702631	1702631	1702631	1702631	1702631	1702631	1702631	1702631
17	--	--	--	--	--	--	--	--
18	--	--	--	--	--	--	--	--
19	--	--	--	--	--	--	--	--

SECTION 4 - MACHINE OPERATION

Item #	ANSI 1001109493-B	CE/Australia 1001110824-C	Japan 1001110825-B	Korea 1001110827-B	Spanish 1001110828-B	French 1001110829-C	Chinese 1001110830-B	Portuguese 1001110831-B
20	1702868	--	--	1705969	1704001	1704000	1705968	1704002
21	1703797	1705921	1703926	1703927	1703923	1703924	1703925	1703928
22	1703798	1705822	1703932	1703933	1703929	1703930	1703931	1703934
23	1703804	1701518	1703950	1703951	1703947	1703948	1703949	1703952
24	1703805	1705961	1703938	1703939	1703935	1703936	1703937	1703940
25	1703813	1705670	1704342	1704343	1704339	1704340	1704344	1704341
26	--	--	--	--	--	--	--	--
27	1704277	1704277	1704277	1704277	1704277	1704277	1704277	1704277
28	1704412	1704412	1704412	1704412	1704412	1704412	1704412	1704412
29	--	--	--	--	--	--	--	--
30	1706126	1706126	1706126	1706126	1706126	1706126	1706126	1706126
31	--	--	--	--	--	--	--	--
32	1707013	--	1707054	1707042	1707049	1707047	1707044	1707133
33	3251243	--	--	--	--	3251243	3251243	--
34	3251813	--	3251813	--	3251813	3251813	3251813	3251813
35	--	--	--	--	--	--	--	--
36	--	--	--	--	--	--	--	--
37	--	--	--	--	--	--	--	--
38	1001110196	1001110196	1001110196	1001110196	1001110196	1001110196	1001110196	1001110196
39	1001110276	--	1001110276	1001110276	1001110276	1001110276	1001110276	1001110276

SECTION 4 - MACHINE OPERATION

Item #	ANSI 1001109493-B	CE/Australia 1001110824-C	Japan 1001110825-B	Korea 1001110827-B	Spanish 1001110828-B	French 1001110829-C	Chinese 1001110830-B	Portuguese 1001110831-B
40	1001110389	--	1001110389	1001110389	1001110389	1001110389	1001110389	1001110389
41	1001112461	1001112461	1001112461	1001112461	1001112461	1001112461	1001112461	1001112461
42	1001112777	1001112777	1001112777	1001112777	1001112777	1001112777	1001112777	1001112777
43	1705351	--	1705426	1705427	1705910	1705429	1705430	1001113680
44	--	1705828	1703980	1703981	1703983	1703984	1703982	1703985
45	--	--	--	--	--	1705514	--	--
46	--	--	--	--	--	--	--	--

SECTION 5. EMERGENCY PROCEDURES

5.1 GENERAL

This section explains the steps to be taken in case of an emergency situation while operating.

5.2 INCIDENT NOTIFICATION

JLG Industries, Inc. must be notified immediately of any incident involving a JLG product. Even if no injury or property damage is evident, the factory should be contacted by telephone and provided with all necessary details.

In USA:

JLG Phone: 877-JLG-SAFE (554-7233)
(8am till 4:45pm EST)

Outside USA:

240-420-2661

E-mail:

ProductSafety@JLG.com

Failure to notify the manufacturer of an incident involving a JLG Industries product within 48 hours of such an occurrence may void any warranty consideration on that particular machine.

NOTICE

FOLLOWING ANY INCIDENT, THOROUGHLY INSPECT THE MACHINE AND TEST ALL FUNCTIONS FIRST FROM THE GROUND CONTROLS, THEN FROM THE PLATFORM CONTROLS. DO NOT LIFT ABOVE 3 M (10 FT.) UNTIL YOU ARE SURE THAT ALL DAMAGE HAS BEEN REPAIRED, IF REQUIRED, AND THAT ALL CONTROLS ARE OPERATING CORRECTLY.

5.3 EMERGENCY OPERATION

Operator Unable to Control Machine

IF THE PLATFORM OPERATOR IS PINNED, TRAPPED OR UNABLE TO OPERATE OR CONTROL MACHINE:

1. Other personnel should operate the machine from ground controls only as required.
2. Other qualified personnel on the platform may use the platform controls. DO NOT CONTINUE OPERATION IF CONTROLS DO NOT FUNCTION PROPERLY.
3. Cranes, forklift trucks or other equipment can be used to stabilize motion of the machine.

SECTION 5 - EMERGENCY PROCEDURES

Platform or Boom Caught Overhead

If the platform or boom becomes jammed or snagged in overhead structures or equipment, rescue platform occupants prior to freeing the machine.

5.4 EMERGENCY TOWING PROCEDURES

Towing this machine is prohibited. However, provisions for moving the machine have been incorporated. The following procedures are to be used ONLY for emergency movement to a suitable maintenance area.

NOTICE

THE ALLOWABLE TOWING SPEED IS 1.9 MPH (3 KPH). THE MAXIMUM ALLOWABLE TOWING DISTANCE IS 0.6 MILES (1 KM).

1. Chock wheels securely.
2. Engage the mechanical release on both drive hubs by loosening, completely reversing, and tightening the two bolts on each hub.
3. Connect suitable equipment, remove chocks, and move machine.

After moving machine, complete the following procedure:

1. Position machine on a firm level surface.
2. Chock wheels securely.

3. Disengage the mechanical release on both drive hubs by loosening, completely reversing, and tightening the two bolts on each hub.
4. Remove chocks from wheels as desired.

5.5 MANUAL DESCENT SYSTEM

(See Figure 5-1., Manual Descent Location)

The manual descent system is used, in the event of total power failure or in case the key is not accessible to the ground personnel, to lower the upper and lower booms using gravity. The jib lift cylinder must be pumped down. To operate the manual descent system, proceed as follows:

1. Locate the manual descent knob on the boom function valve. Push the knob in to lower the tower and pull the knob out to lower the main boom. The knob must be held in place to perform the lowering function; it is spring loaded to return to center when released. Install handle into manual descent pump and lower the selected cylinders by pumping the handle until the boom is completely lowered.
2. If equipped with a jib, locate the split ring on the boom function valve. Push the split ring in to lower the jib or pull the split ring out to raise the jib by pumping the handle until it is completely lowered or raised. Stow the handle in bracket provided.

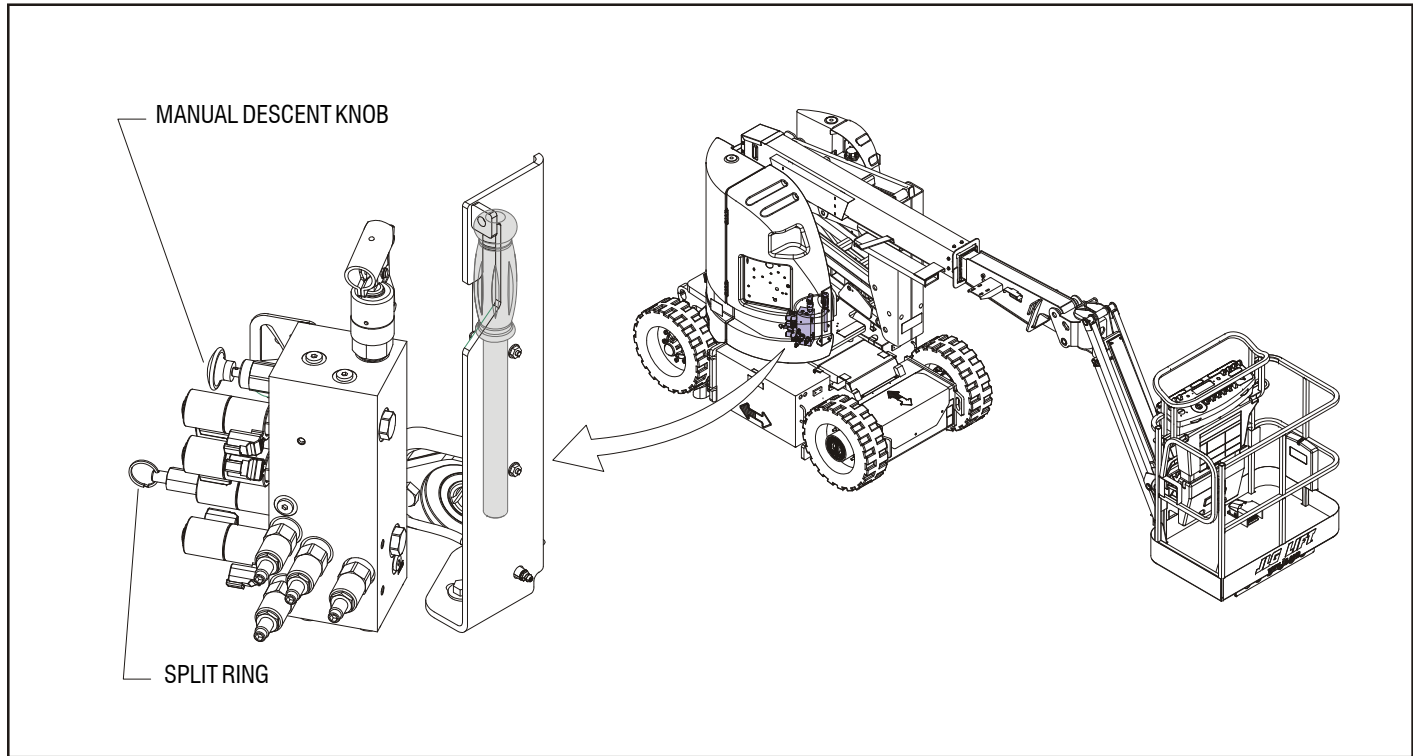

Figure 5-1. Manual Descent Location

5.6 MANUAL SWING OVERRIDE

The manual swing override is used to manually swing the boom and turntable assembly in the event of a total power failure when the platform is positioned over a structure or obstacle. To operate the manual swing override, proceed as follows:

1. Using a 7/8 inch socket and ratchet wrench, locate nut on swing worm gear on left side of machine.
2. Install wrench on nut and ratchet in the direction desired.

SECTION 6. GENERAL SPECIFICATIONS & OPERATOR MAINTENANCE

6.1 INTRODUCTION

This section of the manual provides additional necessary information to the operator for proper operation and maintenance of this machine.

The maintenance portion of this section is intended as information to assist the machine operator to perform daily maintenance tasks only, and does not replace the more thorough Preventive Maintenance and Inspection Schedule included in the Service and Maintenance Manual.

Other Publications Available:

Service and Maintenance Manual 3121253
 Illustrated Parts Manual 3121254

6.2 OPERATING SPECIFICATIONS AND PERFORMANCE DATA

Operating Specifications

Table 6-1. Operating specifications - E300AJ

Capacity: Unrestricted: ANSI	500 lbs. (227 kg)
Capacity: Unrestricted: CE & Australia	500 lbs. (230 kg)
Maximum Travel Grade, stowed Position (Gradeability) see Figure 4-3.	25%
Maximum Travel Grade, stowed Position (Side Slope) see Figure 4-3.	5°
Drive Speed (High Drive) - 200 ft. (60.9 M)	45-50 sec
Drive Speed (Above Horz.) - 50 ft. (15.24 M)	55-68 sec (0.6 mph[0.9 kph])
Gross Machine Weight - Approximate	15060 lbs. (6831 kg)
Ground Bearing Pressure - Maximum	170 psi (11.95 kg/cm ²)
Maximum System Voltage	48V DC

SECTION 6 - GENERAL SPECIFICATIONS & OPERATOR MAINTENANCE

Table 6-1. Operating specifications - E300AJ

Maximum Main Relief Hyd. Pressure	3000 psi (207 bar)
-----------------------------------	--------------------

Table 6-2. Operating specifications - E300AJP

Capacity: Unrestricted: ANSI	500 lbs. (227 kg)
Capacity: Unrestricted: CE & Australia	500 lbs. (230 kg)
Maximum Travel Grade, stowed Position (Gradeability) see Figure 4-3.	25%
Maximum Travel Grade, stowed Position (Side Slope) see Figure 4-3.	5°
Drive Speed (High Drive) - 200ft. (60.9 m)	45-50 sec (3 mph [4.8 kph])
Drive Speed (Above Horz.) - 50 ft. (15.24 M)	55-68 sec (0.6 mph [0.9 kph])
Gross Machine Weight- Approximate	15400 lbs. (6985 kg)
Ground Bearing Pressure - Maximum	170 psi (11.95 kg/cm ²)
Maximum System Voltage	48V DC
Maximum Main Relief Hyd. Pressure	3000 psi (207 bar)

Dimensional Data

Table 6-3. Dimensional Data - E300AJ

Turning Radius (Inside)	5 ft. (1.52 m)
Turning Radius (Outside)	10ft. 2in. (3.1 m)
Machine Height (stowed)	6ft. 7in. (2.01 m)
Machine Length (stowed)	18ft. 2in. (5.54 m)
Up and Over Platform Height	13ft. 2in. (4.01 m)
Horizontal Reach Up and Over	20ft. 3in. (6.17 m)
Machine Width	4ft. (1.22 m)
Wheel Base	5ft. 5in. (1.65 m)
Platform Height	30ft. 2in. (9.19m)
Ground Clearance	4in. (10 cm)

SECTION 6 - GENERAL SPECIFICATIONS & OPERATOR MAINTENANCE

Table 6-4. Dimensional Data - E300AJP

Turning Radius (Inside)	5 ft. (1.52 m)
Turning Radius (Outside)	10ft. 2in. (3.1 m)
Machine Height (stowed)	6ft. 7in. (2.01 m)
Machine Length (stowed)	18ft. 10in. (5.74 m)
Up and Over Platform Height	13ft. 2in. (4.01 m)
Horizontal Reach Up and Over	20ft. 1in. (6.12 m)
Machine Width	4ft. (1.22 m)
Wheel Base	5ft. 5in. (1.65 m)
Platform Height	29ft. 5in. (8.97 m)
Ground Clearance	4in. (10 cm)

Capacities

Table 6-5. Capacities

Hydraulic Oil Tank	2.9 Gal. (11 L) 2.1 Gal. (8 L) to Full Mark
Drive Hub*	25.5 oz. (0.75 L)(1/2 Full)
*Drive hubs should be one half full of lubricant.	

Tires

Table 6-6. Tires

Size	25x7x12
Maximum Tire Load	8200 lbs. (3719 kg)
Type	Solid Non-Marking

SECTION 6 - GENERAL SPECIFICATIONS & OPERATOR MAINTENANCE

Hydraulic Oil

Table 6-7. Hydraulic Oil

Hydraulic System Operating Temperature Range	S.A.E. Viscosity Grade
+0° to +180° F (-18° to +83° C)	10W
+0° to +210° F (-18° to +99° C)	10W-20, 10W30
+50° to +210° F (+10° to +99° C)	20W-20

NOTE: Hydraulic oils require anti-wear qualities at least API Service Classification GL-3, and sufficient chemical stability for mobile hydraulic system service.

NOTE: Machines may be equipped with Mobil EAL224H biodegradable and non-toxic hydraulic oil. This is vegetable oil based and possesses the same antiwear and rust protection characteristics as mineral oils, but will not adversely affect the ground water or the environment when spilled or leaked in small amounts. Mobil EAL224H has a viscosity of 34 cSt at 40° C. and viscosity index of 213. The operating temperature range of this oil is -18° C. to +83° C.

NOTE: Aside from JLG recommendations, it is not advisable to mix oils of different brands or types, as they may not contain the same required additives or be of comparable viscosities. If use of hydraulic oil other than Mobil DTE 11M is desired, contact JLG Industries for proper recommendations.

Table 6-8. Mobil DTE 11M Specs

ISO Viscosity Grade	#15
Gravity API	31.9
Pour Point, Max	-40°F (-40°C)
Flash Point, Min.	330°F (166°C)
Viscosity	
at 40° C	15 cSt
at 100° C	4.1 cSt
at 100° F	80 SUS
at 210° F	43 SUS
cp at -30° F	3.200
Viscosity Index	140

SECTION 6 - GENERAL SPECIFICATIONS & OPERATOR MAINTENANCE

Table 6-9. Mobilfluid 424 Specs

SAE Grade	10W30
Gravity, API	29.0
Density, Lb/Gal. 60°F	7.35
Pour Point, Max	-46°F (-43°C)
Flash Point, Min.	442°F (228°C)
Viscosity	
Brookfield, cP at -18°C	2700
at 40° C	55 cSt
at 100° C	9.3 cSt
Viscosity Index	152

Table 6-10. Mobil EAL 224H Specs

Type	Biodegradable Vegetable Oil
ISO Viscosity Grade	32/46
Specific Gravity	.922
Pour Point, Max	-25°F (-32°C)
Flash Point, Min.	428°F (220°C)
Operating Temp.	0 to 180°F (-17 to 162°C)
Weight	7.64 lb. per gal. (0.9 kg per liter)
Viscosity	
at 40° C	37 cSt
at 100° C	8.4 cSt
Viscosity Index	213
NOTE: Must be stored above 32°F (0°C)	

SECTION 6 - GENERAL SPECIFICATIONS & OPERATOR MAINTENANCE

Table 6-11. Mobil EAL Envirosyn H Specs

Type	Synthetic Biodegradable
ISO Viscosity Grade	32
Specific Gravity	.950
Pour Point, Max	-59°F (-51°C)
Flash Point, Min.	514°F (268°C)
Viscosity	
at 40° C	33.1 cSt
at 100° C	6.36 cSt
Viscosity Index	147

Table 6-12. Quintolubric 888-46

Density	0.91 @ 15°C (59°F)
Pour Point	< -20°C (< -4°F)
Flash Point	275°C (527°F)
Fire Point	325°C (617°F)
Autoignition Temperature	450°C (842°F)
Viscosity	
at 0° C (32°F)	360 cSt
at 20° C (68°F)	102 cSt
at 40° C (104°F)	46 cSt
at 100° C (212°F)	10 cSt
Viscosity Index	220

Major Component Weights

 WARNING

DO NOT REPLACE ITEMS CRITICAL TO STABILITY WITH ITEMS OF DIFFERENT WEIGHT OR SPECIFICATION (FOR EXAMPLE: BATTERIES, FILLED TIRES, PLATFORM) DO NOT MODIFY UNIT IN ANY WAY TO AFFECT STABILITY.

Table 6-13. Critical Stability Weights

Components	LBS.	KG.
Counterweight (AJ)	6188	2807
Counterweight (AJP)	6348	2880
Tire and Wheel	120	54.4
Platform (including console)	169	78
Battery (minimum each) - 305AH	87	39.5
Battery (minimum each) - 375AH & UL	110	50

SECTION 6 - GENERAL SPECIFICATIONS & OPERATOR MAINTENANCE

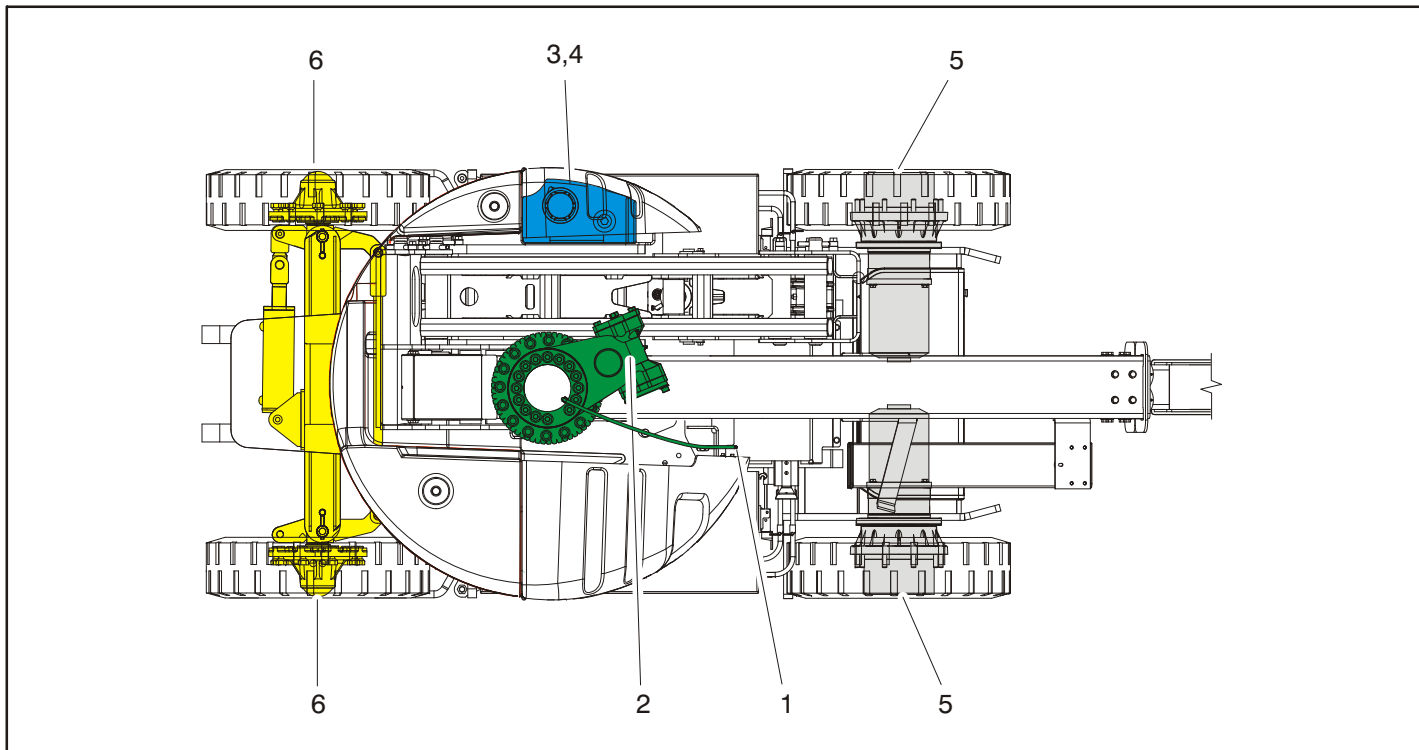

Figure 6-1. Operator Maintenance and Lubrication Diagram

6.3 OPERATOR MAINTENANCE

NOTE: The following numbers correspond to those in Figure 6-1., Operator Maintenance and Lubrication Diagram.

Table 6-14. Lubrication Specifications.

KEY	SPECIFICATIONS
MPG	Multipurpose Grease having a minimum dripping point of 350 degrees F. Excellent water resistance and adhesive qualities; and being of extreme pressure type (Timken OK 40 pounds minimum).
EPGL	Extreme Pressure Gear Lube (oil) meeting API Service Classification GL-5 or Mil-Spec Mil-L-2105.
HO	Hydraulic Oil. Mobil DTE-11M
BG*	Bearing Grease (JLG Part No. 3020029) Mobilith SHA 460.
*MPG may be substituted for these lubricants, if necessary, but service intervals will be reduced.	

NOTICE

LUBRICATION INTERVALS ARE BASED ON MACHINE OPERATION UNDER NORMAL CONDITIONS. FOR MACHINES USED IN MULTI-SHIFT OPERATIONS AND/OR EXPOSED TO HOSTILE ENVIRONMENTS OR CONDITIONS, LUBRICATION FREQUENCIES MUST BE INCREASED ACCORDINGLY.

1. Swing Bearing

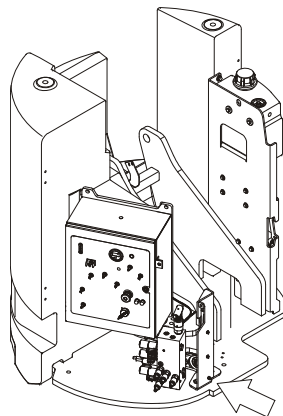

Lube Point(s) - Remote Fitting

Capacity - A/R

Lube - BG

Interval - Every 3 months or 150 hrs of operation

Comments - Apply grease and rotate in 90 degree intervals until bearing is completely lubricated

SECTION 6 - GENERAL SPECIFICATIONS & OPERATOR MAINTENANCE

2. Swing Bearing/Worm Gear Teeth

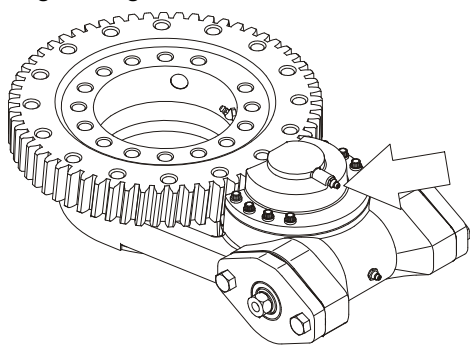

Lube Point(s) - Grease Fitting
Capacity - A/R
Lube - BG
Interval - A/R

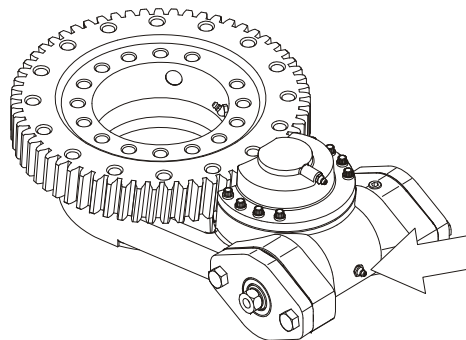

Lube Point(s) - Grease Fitting
Capacity - A/R
Lube - Mobile SHC 007
Interval - A/R

⚠ CAUTION

DO NOT OVERGREASE BEARINGS. OVERGREASING BEARINGS WILL RESULT IN DAMAGE TO OUTER SEAL IN HOUSING.

SECTION 6 - GENERAL SPECIFICATIONS & OPERATOR MAINTENANCE

3. Hydraulic Tank

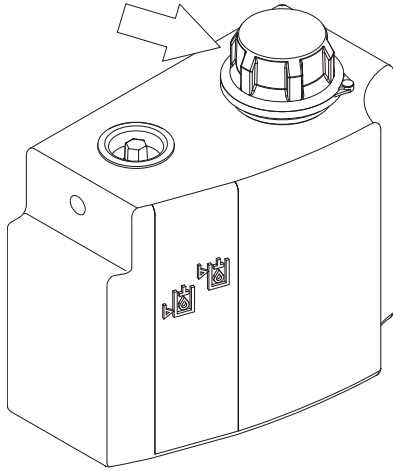

Lube Point(s) - Fill Cap

Capacity - 2.9 Gal. (11 L), 2.1 Gal. (8 L) to Full Mark

Lube - HO

Interval - Check Level daily; Change every 2 years or 1200 hours of operation.

Comments - On new machines, those recently overhauled, or after changing hydraulic oil, operate all systems a minimum of two complete cycles and recheck oil level in reservoir.

4. Hydraulic Return Filter

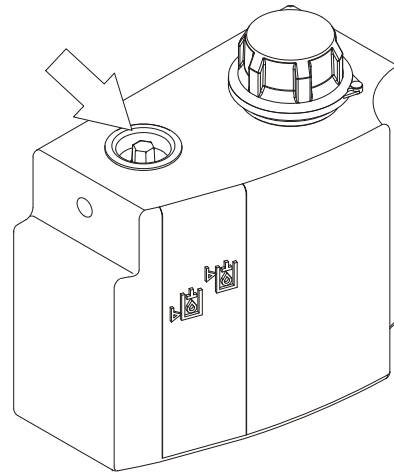

Interval - Change after first 50 hrs. and every 6 months or 300 hrs. thereafter.

Comments - Under certain conditions, it may be necessary to replace the hydraulic filter on a more frequent basis.

SECTION 6 - GENERAL SPECIFICATIONS & OPERATOR MAINTENANCE

5. Wheel Drive Hub

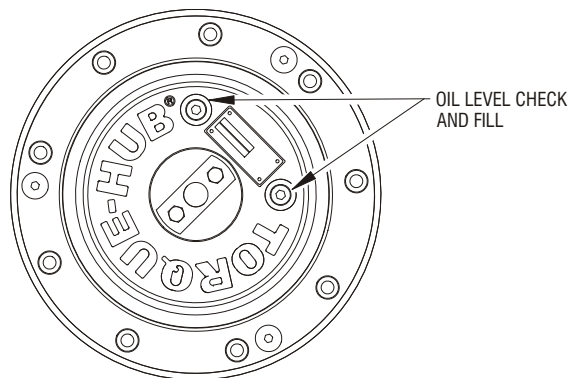

Lube Point(s) - Level/Fill Plug

Capacity - 25.5 oz. (0.75 L)(1/2 Full)

Lube - EPGL

Interval - Check level every 3 months or 150 hrs of operation; change every 2 years or 1200 hours of operation

6. Wheel Bearings

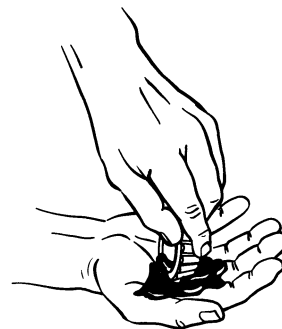

Lube Point(s) - Repack

Capacity - A/R

Lube - MPG

Interval - Every 2 years or 1200 hours of operation

6.4 BATTERY MAINTENANCE AND CHARGING

WARNING

TO AVOID INJURY FROM AN EXPLOSION, DO NOT SMOKE OR ALLOW SPARKS OR A FLAME NEAR BATTERY DURING SERVICING. ALWAYS WEAR EYE AND HAND PROTECTION WHEN SERVICING BATTERIES.

Battery Maintenance, Quarterly

1. Open battery compartment cover to allow access to battery terminals and vent caps.

CAUTION

WHEN ADDING WATER TO BATTERIES, ADD WATER UNTIL ELECTROLYTE COVERS PLATES. DO NOT CHARGE BATTERIES UNLESS ELECTROLYTE COVERS THE PLATES.

NOTE: *When adding distilled water to batteries, non-metallic containers and/or funnels must be used.*

To avoid electrolyte overflow, add distilled water to batteries after charging.

When adding water to the battery, fill only to level indicated or 3/8" (9.5 mm) above separators.

2. Remove all vent caps and inspect electrolyte level of each cell. Electrolyte level should be to the ring approximately one inch from top of battery. Fill batteries with distilled water only. Replace and secure all vent caps.
3. Remove battery cables from each battery post one at a time, negative first. Clean cables with acid neutralizing solution (e.g. baking soda and water or ammonia) and wire brush. Replace cables and/or cable clamp bolts as required.
4. Clean battery post with wire brush then re-connect cable to post. Coat non-contact surfaces with mineral grease or petroleum jelly.
5. When all cables and terminal posts have been cleaned, ensure all cables are properly positioned and do not get pinched. Close battery compartment cover.
6. Start hydraulic system and ensure that it functions properly.

SECTION 6 - GENERAL SPECIFICATIONS & OPERATOR MAINTENANCE

Battery Charging, Daily

NOTE: To avoid excessive battery charging time, do not allow batteries to become completely discharged.

To avoid electrolyte overflow, add distilled water to batteries after charging.

When adding water to the battery, fill only to level indicated or 3/8" above separators.

1. Charge batteries at the end of each work day, or when machine performance is significantly reduced due to batteries becoming discharged.
2. Charge batteries in accordance with the following procedure:
 - a. Open battery compartment, and battery charger compartment covers.

WARNING

WHEN BATTERY CHARGER IS TO BE USED, CHARGING HARNESS MUST BE PLUGGED INTO A GROUNDED RECEPTACLE. IF RECEPTACLE IS NOT GROUNDED AND A MALFUNCTION SHOULD OCCUR, THE MACHINE COULD CAUSE SERIOUS ELECTRICAL SHOCK.

- b. Remove charging harness cable and connect to a receptacle or the correct voltage.
- c. Allow batteries to charge until 100% LED is illuminated.

NOTE: When batteries are completely charged, disconnect charging harness cable from receptacle. Store charging harness cable.

- d. Ensure battery cables are properly positioned and are not pinched. Close and secure all compartment doors.

6.5 TIRES & WHEELS

Tire Replacement

JLG recommends a replacement tire be the same size, ply and brand as originally installed on the machine. Please refer to the JLG Parts Manual for the part number of the approved tires for a particular machine model. If not using a JLG approved replacement tire, we recommend that replacement tires have the following characteristics:

- Equal or greater ply/load rating and size of original
- Tire tread contact width equal or greater than original
- Wheel diameter, width, and offset dimensions equal to the original
- Approved for the application by the tire manufacturer (including inflation pressure and maximum tire load)

Unless specifically approved by JLG Industries Inc. do not replace a foam filled or ballast filled tire assembly with a pneumatic tire. When selecting and installing a replacement tire, ensure that all tires are inflated to the pressure recommended by JLG. Due to size variations between tire brands, both tires on the same axle should be the same.

Wheel and Tire Replacement

The rims installed on each product model have been designed for stability requirements which consist of track width, tire pressure, and load capacity. Size changes such as rim width, center piece location, larger or smaller diameter, etc., without written factory recommendations, may result in an unsafe condition regarding stability.

Wheel Installation

It is extremely important to apply and maintain proper wheel mounting torque.

WARNING

WHEEL NUTS MUST BE INSTALLED AND MAINTAINED AT THE PROPER TORQUE TO PREVENT LOOSE WHEELS, BROKEN STUDS, AND POSSIBLE DANGEROUS SEPARATION OF WHEEL FROM THE AXLE. BE SURE TO USE ONLY THE NUTS MATCHED TO THE CONE ANGLE OF THE WHEEL.

Tighten the lug nuts to the proper torque to prevent wheels from coming loose. Use a torque wrench to tighten the fasteners. If you do not have a torque wrench, tighten the fasteners with a lug wrench, then immediately have a service garage or dealer tighten the lug nuts to the proper torque. Over-tightening will result in breaking the studs or permanently deforming the

SECTION 6 - GENERAL SPECIFICATIONS & OPERATOR MAINTENANCE

mounting stud holes in the wheels. The proper procedure for attaching wheels is as follows:

1. Start all nuts by hand to prevent cross threading. DO NOT use a lubricant on threads or nuts.
2. Tighten nuts in the following sequence.

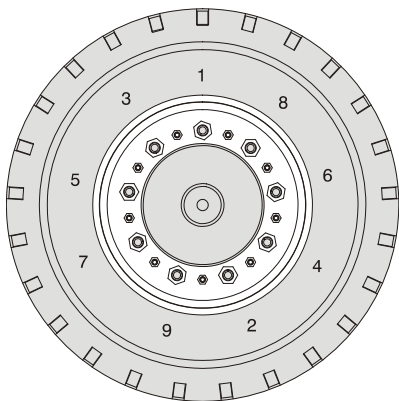

3. The tightening of the nuts should be done in stages. Following the recommended sequence, tighten nuts per wheel torque.
4. Wheel nuts should be torqued after first 50 hours of operation and after each wheel removal. Check the torque after the first 10 miles, 25 miles, and again at 50 miles. Check periodically thereafter.

Table 6-15. Wheel Torque Chart

TORQUE SEQUENCE		
1st Stage	2nd Stage	3rd Stage
40 ft lbs (55 Nm)	95 ft lbs (130 Nm)	170 ft lbs (230 Nm)

6.6 SUPPLEMENTAL INFORMATION

The following information is provided in accordance with the requirements of the European Machinery Directive 2006/42/EC and is only applicable to CE machines.

For electric powered machines, the equivalent continuous A-Weighted sound pressure level at the work platform is less than 70dB(A)

For combustion engine powered machines, guaranteed Sound Power Level (LWA) per European Directive 2000/14/EC (Noise Emission in the Environment by Equipment for Use Outdoors) based on test methods in accordance with Annex III, Part B, Method 1 and 0 of the directive, is 104 dB.

The vibration total value to which the hand-arm system is subjected does not exceed $2,5 \text{ m/s}^2$. The highest root mean square value of weighted acceleration to which the whole body is subjected does not exceed $0,5 \text{ m/s}^2$.

SECTION 7. INSPECTION AND REPAIR LOG

Machine Serial Number _____

Table 7-1. Inspection and Repair Log

Date	Comments

SECTION 7 - INSPECTION AND REPAIR LOG

Table 7-1. Inspection and Repair Log

Date	Comments



An Oshkosh Corporation Company

TRANSFER OF OWNERSHIP

To Product Owner:

If you now own but **ARE NOT** the original purchaser of the product covered by this manual, we would like to know who you are. For the purpose of receiving safety-related bulletins, it is very important to keep JLG Industries, Inc. updated with the current ownership of all JLG products. JLG maintains owner information for each JLG product and uses this information in cases where owner notification is necessary.

Please use this form to provide JLG with updated information with regard to the current ownership of JLG products. Please return completed form to the JLG Product Safety & Reliability Department via facsimile or mail to address as specified below.

Thank You,
Product Safety & Reliability Department
JLG Industries, Inc.
13224 Fountainhead Plaza
Hagerstown, MD 21742
USA
Telephone: +1-717-485-6591
Fax: +1-301-745-3713

NOTE: Leased or rented units should not be included on this form.

Mfg. Model: _____

Serial Number: _____

Previous Owner: _____

Address: _____

Country: _____ Telephone: (____) _____

Date of Transfer: _____

Current Owner: _____

Address: _____

Country: _____ Telephone: (____) _____

Who in your organization should we notify?

Name: _____

Title: _____



WARNING:



The engine exhaust from this product contains chemicals known to the State of California to cause cancer, birth defects, or other reproductive harm.

1702961

PROPOSITION 65 WARNING

- **Battery posts, terminals and related accessories contain lead and lead compounds, chemicals known to the State of California to cause cancer and reproductive harm.**
- **Batteries also contain other chemicals known to the State of California to cause cancer.**
- **Wash hands after handling.**



An Oshkosh Corporation Company

Corporate Office
JLG Industries, Inc.
1 JLG Drive
McConnellsburg PA. 17233-9533
USA

(717) 485-5161

(717) 485-6417



3121252

JLG Worldwide Locations

JLG Industries (Australia)
P.O. Box 5119
11 Bolwarra Road
Port Macquarie
N.S.W. 2444
Australia

+61 2 65 811111

+61 2 65813058

JLG Latino Americana Ltda.
Rua Eng. Carlos Stevenson,
80-Suite 71
13092-310 Campinas-SP
Brazil

+55 19 3295 0407

+55 19 3295 1025

JLG Industries (UK) Ltd
Bentley House
Bentley Avenue
Middleton
Greater Manchester
M24 2GP - England

+44 (0)161 654 1000

+44 (0)161 654 1001

JLG France SAS
Z.I. de Baulieu
47400 Fauillet
France

+33 (0)5 53 88 31 70

+33 (0)5 53 88 31 79

JLG Deutschland GmbH
Max-Planck-Str. 21
D - 27721 Ritterhude - Ihlpohl
Germany

+49 (0)421 69 350 20

+49 (0)421 69 350 45

JLG Equipment Services Ltd.
Rm 1107 Landmark North
39 Lung Sum Avenue
Sheung Shui N. T.
Hong Kong

(852) 2639 5783

(852) 2639 5797

JLG Industries (Italia) s.r.l.
Via Po. 22
20010 Pregnana Milanese - MI
Italy

+39 029 359 5210

+39 029 359 5845

Oshkosh-JLG Singapore Technology
Equipment Pte Ltd
29 Tuas Ave 4,
Jurong Industrial Estate
Singapore, 639379

+65-6591 9030

+65-6591 9031

Plataformas Elevadoras
JLG Iberica, S.L.
Trapadella, 2
P.I. Castellbisbal Sur
08755 Castellbisbal, Barcelona
Spain

+34 93 772 4700

+34 93 771 1762

JLG Sverige AB
Enkopingsvagen 150
Box 704
SE - 176 27 Jarfalla
Sweden

+46 (0)850 659 500

+46 (0)850 659 534